

Schwerpunkt SP (2W35)
gravity centre SP (2W35)

- ohne Oel, ohne Kuehlmittel
- without oil, without coolant
- incl. LF, Krst.-Filter, SD, Anlasser, Oelfilter
- incl. air filter, fuel filter, exhaust silencer, starter motor, oil filter
- ohne Luefter
- without cooling fan

Massentraegheitsmoment
mass moment of inertia

$J_{xs} = 1.253 \text{ kgm}^2$
$J_{ys} = 1.970 \text{ kgm}^2$
$J_{zs} = 2.137 \text{ kgm}^2$

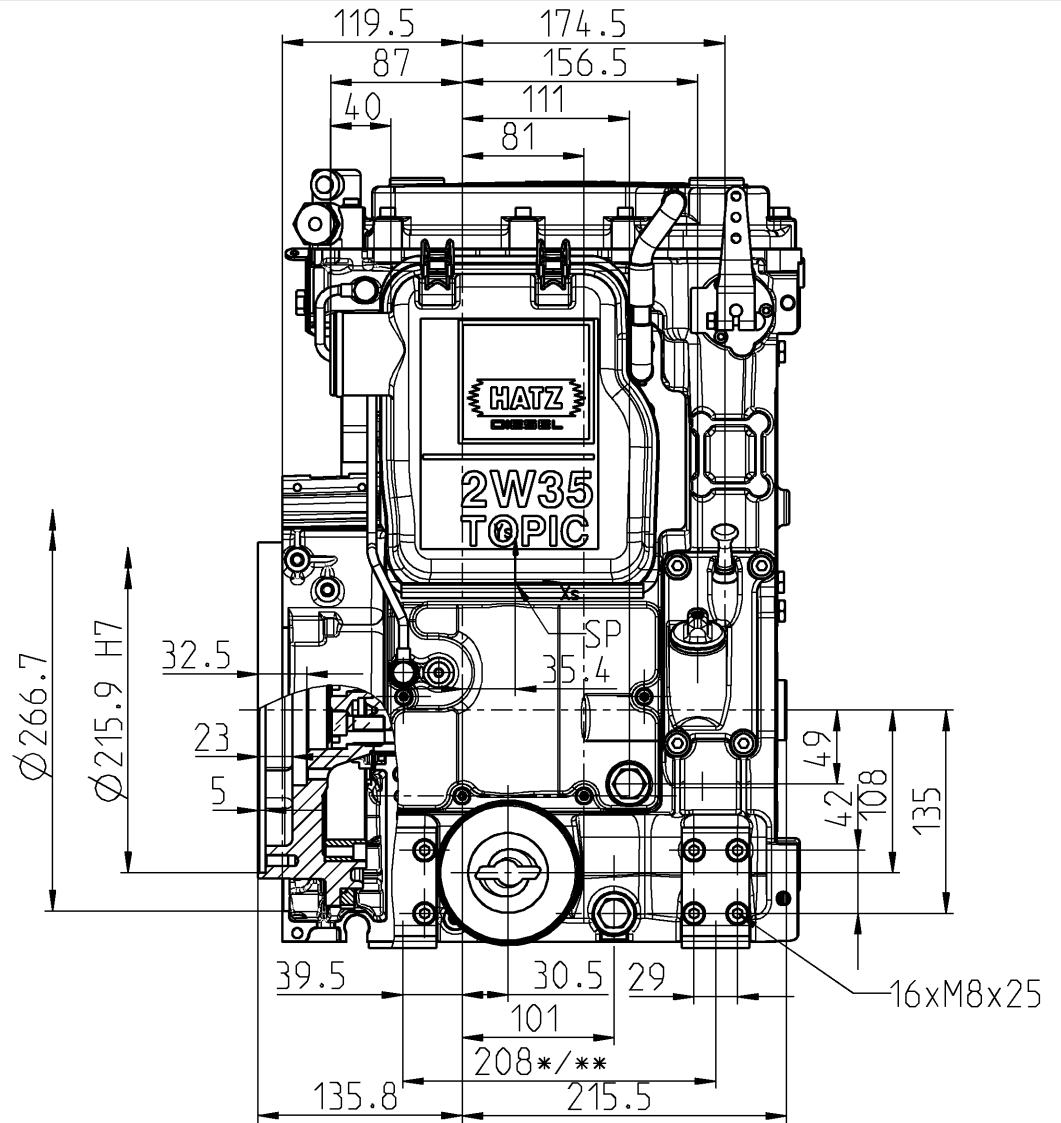
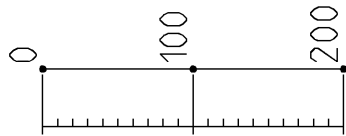

Nr.	Datum	Name	Änderung

HATZ
DIESEL
MOTORENFABRIK
HATZ
RUHSTORF-ROTT

INSTALLATION DRAWING
EINBAUZEICHNUNG
2W 35

SHEET OF SHEETS
Blatt 2 von 4 Blättern

Gez.	21.03.06	Frey	Gepr.	--	--
------	----------	------	-------	----	----

In the interests of technical progress we reserve the right to introduce modification	PROTECTION MARK ACC. TO DIN ISO 16016
Aenderungen, die dem technischen Fortschritt dienen, behalten wir uns vor.	Schutzvermerk nach DIN ISO 16016 beachten
The range of the length over-all based on tolerances can add up $\pm 3\text{mm}$	Toleranzbedingte Streubreite bei Kastenmaßen $\pm 3\text{mm}$