

CREATING POWER SOLUTIONS.

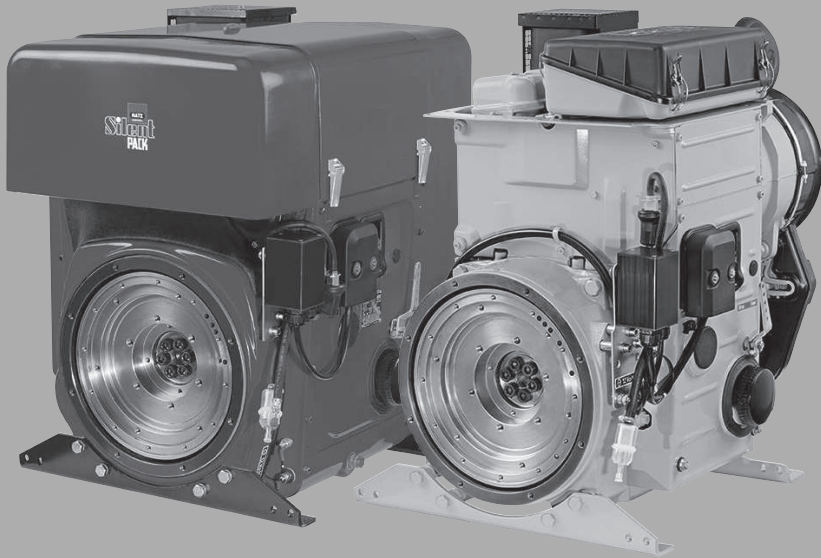

INCLUDES SUPPLEMENTAL INFORMATION TO THE OWNER'S MANUAL FOR MODEL YEAR 2019 EPA CERTIFIED NONROAD COMPRESSION-IGNITION ENGINES.

INCLUDES SUPPLEMENTAL INFORMATION FOR THE USE OF EPA CERTIFIED ENGINES WITHIN CALIFORNIA.

2L41C | 2M41 | 2M41Z

OPERATOR'S MANUAL Diesel engine

Hatz Diesel

www.hatz-diesel.com

1	Notices	5
2	General information	6
3	Safety	7
3.1	General information	7
3.1.1	Intended use and foreseeable misuse	7
3.1.2	Machine user or machine manufacturer obligations	8
3.1.3	Representation of safety notes	9
3.1.4	Meaning of safety symbols	10
3.2	Safety notes	12
3.2.1	Operational safety	12
3.2.2	Machine-specific safety instructions for operation	15
3.2.3	Machine-specific safety instructions for maintenance work	16
3.2.4	Electrical equipment	18
3.3	Labels	20
4	Technical data	21
4.1	Engine information and filling quantities	21
4.2	Engine type plate	22
4.3	Physical operating conditions	23
4.4	Engine oil	24
4.5	Fuel	25
5	Engine design	26
6	Transport, assembly and commissioning	29
6.1	Transport	29
6.2	Installation notes	30
6.3	Preparations for commissioning	31
6.4	Filling engine oil (first filling)	31
7	Operation and use	33
7.1	Safety notes	33
7.2	Performing tests	34
7.3	Start preparation	34
7.3.1	Pumping fuel with the manual lever	34
7.4	Setting the speed control	36
7.5	Starting the engine	36
7.5.1	Starting the engine with crankhandle	37
7.5.2	Starting the engine with a starter	42
7.6	Switching off the engine	45
7.6.1	Switching off the engine (mechanical)	46
7.6.2	Switching off the engine (electrical)	47
7.7	Refueling	48
7.8	Check the oil level	49

8	Maintenance	51
8.1	General maintenance instructions	51
8.2	Maintenance work.....	52
8.2.1	Maintenance notice label	52
8.2.2	Maintenance plan	54
8.2.3	Checking the intake area of the combustion air.....	56
8.2.4	Checking the cooling air area	59
8.2.5	Change the engine oil.....	60
8.2.6	Checking the poly v belt.....	62
8.2.7	Cleaning the cooling fan, cooling fins and oil cooler	63
8.2.8	Checking the screw connections	67
8.2.9	Cleaning the screen insert in the exhaust pipe (additional equipment)	67
8.2.10	Changing the fuel prefilter.....	69
8.2.11	Maintaining the dry air filter.....	71
8.2.12	Checking and cleaning the air filter cartridge.....	73
8.2.13	Check and set the tappet clearance	75
8.2.14	Changing the oil filter	78
8.2.15	Change the main fuel filter	79
8.2.16	Checking that the air filter maintenance indicator is working properly	81
8.2.17	Renewing the poly v belt and checking the function of the switch-off unit.....	83
9	Faults.....	87
9.1	Troubleshooting	87
9.2	Emergency start.....	92
10	Storage and disposal.....	95
10.1	Storing the machine	95
10.2	Disposing of the machine	97
11	Proof of quality.....	98
12	EPA CERTIFIED ENGINES.....	99
13	EPA CERTIFIED ENGINES WITHIN CALIFORNIA.....	109

1 Notices

Contact data

© 2018
Motorenfabrik HATZ
Ernst-Hatz-Straße 16
94099 Ruhstorf
Germany
Tel. +49 (0)8531 319-0
Fax +49 (0)8531 319-418
marketing@hatz-diesel.de
www.hatz-diesel.com
All rights reserved!

Copyright

The copyright for this manual rests entirely with Motorenfabrik HATZ, Ruhstorf.

This manual may only be copied or distributed if written approval has been received. This also applies to the copying or distribution of excerpts of this manual. The same conditions apply to distribution of this manual to third parties in digital form.

Original manual

This manual has been translated into multiple languages.

The German version is the **original manual**. All other language versions are **translations** of the **original manual**.

2 General information

Information on the document

This manual was created with due care. It is exclusively intended to offer a technical description of the machine and to provide instructions on commissioning, operating and maintaining the machine. When operating the machine, the applicable standards and legal regulations as well as any in-house regulations apply.

Before commissioning, during operation and before maintenance work is begun on the machine, read this manual carefully and keep it close by for ready access.

Machine

This manual describes the following machine.

Machine name	HATZ diesel engine
Type number	2L41C, 2M41, 2M41Z

Customer service

Have service work performed by qualified technicians only. We recommend that you work with one of the over 500 **HATZ service stations**. Trained specialists there will repair your machine with **Hatz original spare parts** and with **HATZ tools**. The global HATZ service network is at your disposal to advise you and supply you with spare parts. For the address of the **Hatz service station** nearest you, please see the enclosed spare parts list or visit us in the Internet at: **www.hatz-diesel.com**

Installation of unsuitable spare parts can lead to problems. We cannot accept responsibility for direct damage or secondary damage that results from this.

We therefore recommend the use of **Hatz original spare parts**. These parts are manufactured according to strict Hatz specifications and achieve maximum operational reliability through their perfect fit and functionality. The order number can be found in the enclosed spare parts list or on the Internet at: **www.hatz-diesel.com**

Exclusion of liability

The manufacturer cannot be held responsible for personal injury, damage to property or damage to the machine itself caused by improper use, foreseeable misuse, or failure to follow or adequately follow the safety measures and procedures described in this manual. This also applies to changes made to the machine and the use of unsuitable spare parts.

Modifications, which serve the technical improvements, are reserved

3 Safety

3.1 General information

Introduction

This chapter contains the information you need to work safely with this machine.

To prevent accidents and damage to the machine, it is imperative that these safety instructions be followed.

Read this chapter carefully before beginning work.

3.1.1 Intended use and foreseeable misuse

Intended use

The machine described in this manual fulfills the following functions:

- Diesel engine intended for installation in a machine or for assembly with other machines to form a machine. See chapter *11 Proof of quality*, page 98.

This engine is intended exclusively for the purpose specified and tested by the manufacturer of the machine in which the engine is installed.

Any other use is not intended and therefore not permitted. Violations compromise the safety of the personnel working with the machine. Motorenfabrik HATZ does not accept any liability for damage resulting from this.

The operational safety of the machine is only guaranteed if it is used as intended.

The intended use also includes observance of the instructions in this Operator's Manual to preserve the environment, including in the appendix for the model year 2019 as per EPA Nonroad Diesel Engines.

Foreseeable misuse

The following is considered to be foreseeable misuse:

- Any use that varies from or extends beyond the uses specified above.
- Failure to comply with the instructions given in this manual.
- Failure to comply with the safety instructions.
- Failure to immediately eliminate malfunctions that impact safety before continuing work with the machine (working with the machine when it is not in perfect condition, either functionally or in terms of safety).
- Failure to perform the necessary inspection and maintenance work.
- Any unauthorized modification of or removal of safety equipment.
- Use of spare parts and accessories that are unsuitable or have not been approved by HATZ.
- Operation in flammable or hazardous environments.
- Operation in closed-off or poorly ventilated rooms.

- Installation of the machine in mobile equipment (e.g. vehicles, trailers) or in closed rooms without additional measures to handle supply air, extract air, and exhaust gas.
- Improper operation at variance with DIN 6271 and DIN ISO 8528 (climate, load, safety).

Residual risks

Residual risks result during daily use and in association with maintenance work.

These residual risks will be pointed out in chapter 3.2.2 *Machine-specific safety instructions for operation, page 15* and in chapter 3.2.3 *Machine-specific safety instructions for maintenance work, page 16* as well as in the further contents of the manual, directly in front of the descriptions or operating instructions concerned.

3.1.2 Machine user or machine manufacturer obligations

Machine manufacturer obligations

If you have an engine that is not yet installed in a machine, it is imperative that you follow the **Assembly Instructions for HATZ Diesel Engines** before installing the engine. These assembly instructions contain important information on how to safely install the engine and are available at your nearest **HATZ service station**.

It is prohibited to start the engine before it is fully installed.

In addition, please note that it is prohibited to start up the machine before it has been determined that the machine into which this engine is installed fulfills all safety-related requirements and legal regulations.

User obligations

The operator is obliged to only operate the machine when it is in perfect condition. The operator must check the condition of the machine before use and ensure that any defects are eliminated before it is taken into service. Running the machine while identified defects exist is not permitted. The user must also ensure that all persons who work on the machine are familiar with the contents of this manual.

Obligations of the operating and maintenance personnel

Personnel assigned with operating and maintaining the machine must have read and understood this manual or must possess the qualifications necessary for working with this equipment, acquired in training/instructional courses. No one may work with the machine without the necessary qualifications, even if for just a brief period.

The operating and maintenance personnel must not be under the influence of drugs, medication or alcohol.

All work performed on the machine must be in compliance with the information provided in this manual.

Storing this manual

This manual is an integral component of the machine (also when being sold). It must be stored in the direct vicinity of the machine and be accessible to personnel at all times.

3.1.3 Representation of safety notes

Overview

This machine has been designed and built according to state-of-the-art technology and the recognized safety standards. Despite these precautions, risks exist when operating the machine and during maintenance work.

These risks are identified in this manual by means of safety notes.

The safety notes precede the related description or operating step.

Structure of the safety notes

The safety notes consist of:

- Danger symbol
- signal word
- Description of danger
- Possible consequences
- Preventative measures



General danger symbol



The general danger symbol is used to identify the danger of personal injury.

Signal words





Signal words identify the magnitude of the risk and the seriousness of the possible injuries:







Danger symbol/ signal word	Meaning
 DANGER	This signal word is used to indicate imminently dangerous situations which, if not avoided, will lead to serious injury or death.
 WARNING	This signal word is used to indicate potentially dangerous situations which, if not avoided, may lead to serious injury or death.
 CAUTION	This signal word is used to indicate potentially dangerous situations which, if not avoided, may lead to minor or moderate injury.
CAUTION	This signal word, without a danger symbol, is used to indicate the risk of property damage.
NOTICE	This signal word indicates additional useful information, such as operating tips and cross references.

3.1.4 Meaning of safety symbols

Explanation of symbols

The following table describes the meanings of the safety symbols used in this manual.

Symbol	Meaning
	Smoking, fire, and open flames are prohibited!
	Warning of personal injury!
	Warning of hot surfaces!
	Warning of flammable substances!



Symbol	Meaning
	Warning of explosive substances!
	Warning of toxic engine exhaust!
	Warning of corrosive substances!
	Warning of heavy loads!
	Warning of environmental damage!
	Comply with this manual or additional documentation from other manufacturers or the carrier.
	Additional information that is useful to the reader.

3.2 Safety notes

3.2.1 Operational safety

Introduction

This chapter contains all of the important safety instructions for personal protection and for safe and reliable operation. Additional, task-related safety instructions can be found at the beginning of each chapter.

 DANGER	
	<p>Danger to life, danger of injury or danger of property damage due to failure to comply with this manual and the safety instructions contained therein.</p> <ul style="list-style-type: none"> ▪ As the operator of the machine, you must ensure that all people working on the machine are familiar with the content of this manual. ▪ Before working on the machine, read this manual carefully, paying special attention to the safety notes. ▪ Fulfill all required safety conditions before working on the machine. ▪ Follow all general safety instructions as well as the specific task-related safety instructions contained in the individual chapters.

Using the machine

- Only operate the machine for the purposes described in chapter 3.1.1 *Intended use and foreseeable misuse*, page 7.

Compliance with other regulations

- Adhere to the applicable accident prevention regulations of the trade associations.
- Comply with the regulations concerning the minimum safety and health requirements for the use of work equipment by workers at work.
- In addition, local safety, accident prevention and environmental regulations also apply when operating the machine.

Personal protective equipment

During operation and maintenance of the machine, personal protective equipment must be available and must be used if necessary. The required personal protective equipment is specified in the descriptions of the operating steps.

Personal protective equipment	Pictogram	Function
Safety shoes		Safety shoes offer protection against: <ul style="list-style-type: none"> ▪ Slipping ▪ Falling objects
Hearing protection		Hearing protection offers protection against ear injuries due to excessive and constant noise.
Safety gloves		Safety gloves protect the hands against injury, e.g. from battery acid.
Safety goggles (with side protection)		Safety goggles protect the eyes from flying objects (e.g. dust particles, spraying liquids, spraying acid).
Working clothes		Wear close-fitting clothing. However, it must not restrict the wearer's freedom of movement.

Warning labels and information signs on the machine

The warning labels and information signs on the machine must be followed (see chapter "Labels" 3.3 *Labels*, page 20).

The warning labels and information signs must be kept legible and must be replaced if necessary. For this purpose, contact your nearest **HATZ service station**.

Maintenance work









Maintenance work that goes beyond the scope described in this manual must only be performed by qualified technicians (see chapter 2 *General information*, page 6).

Independent maintenance work and constructional changes to the machine, especially to the safety equipment, are not permitted.

Safety equipment

Safety equipment must not be modified and must not be rendered ineffective during normal operation.

General safety instructions

 DANGER	
	<p>Danger to life and danger of injury due to failure to follow the warnings on the machine and in this manual.</p> <ul style="list-style-type: none"> ▪ Heed the warnings on the machine and in this manual.
 WARNING	
	<p>Danger of injury and danger of incorrect operation due to inadequate personnel qualifications.</p> <ul style="list-style-type: none"> ▪ The personnel must have read and understood this manual or must possess the qualifications necessary for working with this equipment, acquired in training/instructional courses. ▪ Only qualified personnel is permitted to operate and maintain this machine. ▪ Failure to comply will cause the warranty to become void.
 WARNING	
	<p>Danger of injury from failure to follow the operating instructions and from performing unauthorized tasks on the machine.</p> <ul style="list-style-type: none"> ▪ Follow all instructions. ▪ Do not perform activities for which no qualification is available. Contact properly trained personnel if necessary.
 CAUTION	
	<p>Danger of injury from overloading the body.</p> <p>Lifting the machine to transport it or to move it to another location can lead to injuries (of the back, for example).</p> <ul style="list-style-type: none"> ▪ Only lift the machine with a hoist (see chapter 6.1 <i>Transport</i>, page 29).

3.2.2 Machine-specific safety instructions for operation

Introduction

The machine can pose residual risks during operation. To eliminate these risks, all persons working on the machine must follow the general and machine-specific safety instructions.

If you have an engine that is not yet installed in a machine, it is imperative that you follow the **Assembly Instructions for HATZ Diesel Engines** before installing the engine.

These assembly instructions contain important information on safe installation.

If the engine is installed in a machine or assembled with other machines to form a machine, it is prohibited to start the engine before it has been determined that the newly created machine fulfills all safety-related requirements and applicable legal regulations.



Safe operation



- Before switching on the machine, ensure that no one can be injured when the machine is started up.
- During machine operation, ensure that unauthorized persons do not have access to the area in which the machine has an impact.
- Parts of the exhaust gas system and the surface of the engine become hot during operation. Risk of injury from touching hot parts! Let the engine cool before maintenance.
- Do not refuel during operation.

Faults

- Immediately eliminate faults that compromise safety.
- Switch off the machine and do not take into service again until all faults have been eliminated.

Safety instructions for operation

 DANGER	
	<p>Danger to life from inhaling exhaust gases.</p> <p>Toxic engine exhaust gases can lead to loss of consciousness and even death in closed-off and poorly ventilated rooms.</p> <ul style="list-style-type: none"> ▪ Never operate the machine in closed-off or poorly ventilated rooms. ▪ Do not breathe in the exhaust gases.

 DANGER	
 	<p>Fire hazard from fuel.</p> <p>Leaked or spilled fuel can ignite on hot engine parts and cause serious burn injuries.</p> <ul style="list-style-type: none"> ▪ Only refuel when the engine is switched off. ▪ Never refuel in the vicinity of open flames or sparks that can cause ignition. ▪ Do not smoke. ▪ Do not spill fuel.

3.2.3 Machine-specific safety instructions for maintenance work

Introduction

The machine can pose residual risks during maintenance. To eliminate these risks, all persons working on the machine must follow the general and machine-specific safety instructions.

Maintenance intervals

- Strictly adhere to the maintenance intervals.
Regular maintenance according to the instructions in this manual is essential for ensuring reliable operation and the correct engine exhaust quality.
- Check the safety equipment regularly to ensure it is in good condition and functioning properly.
- Check connections, cables and fasteners regularly to ensure they are in good condition.

Maintenance work

Maintenance work that goes beyond the scope described in this manual must only be performed by qualified technicians. We recommend that you work with one of the over 500 **HATZ service stations**.









Replacing parts

- When replacing defective components, we recommend that you use **genuine HATZ original spare parts** (see chapter 2 *General information*, page 6).
- When disposing of parts that can no longer be used, do so in accordance with local environmental regulations or send them to a recycling center.

Measures following maintenance and troubleshooting







- Securely reconnect loose electrical connections; check that the electrical components and equipment are functioning properly.
- Check the entire machine for foreign bodies; remove any foreign bodies.

Safety instructions for maintenance work

 DANGER	
	<p>Danger of explosion from flammable cleaning agents.</p> <p>Cleaning with benzene is an explosion hazard. It is highly flammable, can become electrostatically charged, and can generate an explosive gas/air mixture.</p> <ul style="list-style-type: none"> ▪ Use halogen-free, cold cleaners with a high flashpoint for cleaning. ▪ Comply with manufacturer's instructions.
 WARNING	
 	<p>Danger of injury from compressed air and dust particles.</p> <p>Eye injuries may occur when cleaning with compressed air.</p> <ul style="list-style-type: none"> ▪ Wear safety goggles.
 CAUTION	
	<p>Danger of injury if maintenance instructions are not followed.</p> <ul style="list-style-type: none"> ▪ Only perform maintenance when the engine is switched off. ▪ For engines with an electric starter: Disconnect the negative battery terminal. Protect the starting key against unauthorized access.
 CAUTION	
	<p>Danger of burns.</p> <p>There is a danger of burns when working on a hot engine.</p> <ul style="list-style-type: none"> ▪ Let the engine cool before maintenance.

3.2.4 Electrical equipment

Safety notes



 DANGER	
	<p>Danger to life, danger of injury or danger of property damage due to incorrect use of batteries.</p> <ul style="list-style-type: none"> ▪ Do not place tools or other metal objects on the battery. ▪ Before performing work on the electrical equipment, always disconnect the negative battery terminal. ▪ Never swap the positive (+) and negative (–) battery terminals. ▪ When installing the battery, first connect the positive cable and then the negative cable. ▪ When removing the battery, first disconnect the negative cable and then the positive cable. ▪ It is imperative to prevent short circuits and mass contact of current carrying cables. ▪ If faults occur, check the cable connections for good contact.
 DANGER	
	<p>Danger of explosion from flammable substances.</p> <p>There is a danger of explosion from flammable gases.</p> <ul style="list-style-type: none"> ▪ Keep batteries away from open flames and incendiary sparks. ▪ Do not smoke when working with batteries.
 CAUTION	
	<p>Danger of chemical burns</p> <p>Chemical burns can occur when using batteries for the electrical operation.</p> <ul style="list-style-type: none"> ▪ Protect your eyes, skin, and clothing from corrosive battery acid. ▪ Immediately rinse areas affected by splashed acid with clear water and consult a physician if necessary.

NOTICE

- The necessary wiring diagrams are included with the machine if it is equipped with electrical equipment. Additional wiring diagrams can be requested when needed.
 - We cannot be held liable for electrical equipment that is not designed according to HATZ wiring diagrams.
-
- Promptly replace faulty indicator lamps.
 - Do not pull out the starting key during operation.
 - Do not disconnect the battery while the machine is running. Resulting voltage peaks could destroy the electronic components.
 - When performing a manual emergency start, leave the (possibly depleted) battery connected.
 - When cleaning, do not spray the electrical equipment components with a water jet or high pressure cleaner.
 - When performing welding work on the machine, disconnect the battery and place the ground clamp of the welding equipment as close as possible to the welding area. Disconnect the plug-in connection to the voltage regulator.

3.3 Labels

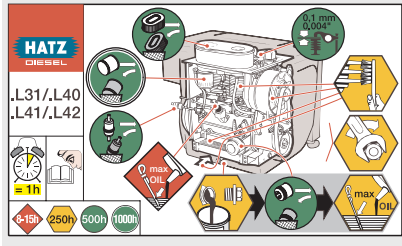
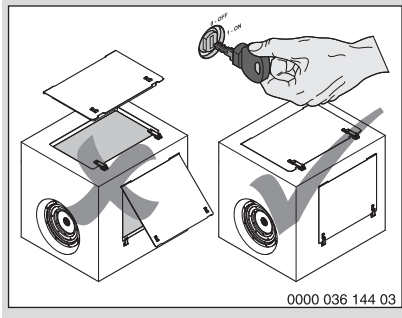
Warning labels and information signs on the engine

Label	Meaning
	<p>Maintenance instructions (see the chapter 8.1 <i>General maintenance instructions</i>, page 51)</p>
	<p>CAUTION! Damage from inadequate engine cooling.</p> <ul style="list-style-type: none"> Only run the engine when all covers are installed.
	<p>Refuel with diesel fuel only. Specification, see the chapter 4.5 <i>Fuel</i>, page 25</p> <p>Do not use bio diesel.</p>
	<p>The engine may only be operated with fuel that is "EXTREMELY LOW IN SULFUR".</p> <p>The fuel label is located close to the fuel cap. If there is no fuel tank installed on the engine, the label must be applied permanently close to the fuel filler opening.</p>

Warning labels and information signs on the crankhandle

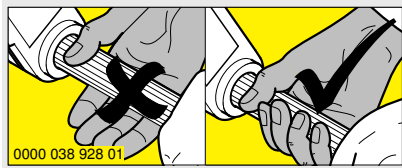
Label	Meaning
	<p>Hold the handle bar so that it cannot twist and quickly turn the crank so that continuous traction between the engine and crank is ensured, see chapter 7.5.1 <i>Starting the engine with crankhandle</i>, page 37.</p>

4 Technical data

4.1 Engine information and filling quantities

Type		2L41C, 2M41, 2M41Z
Type		Air-cooled four stroke diesel engine
Combustion system		Direct injection
Number of cylinders		2
Bore/stroke	mm	102 / 105
Displacement	cm ³	1716
Engine oil pressure at oil temperature of 100 ± 20 °C		Min. 0.6 bar at 850 rpm
Engine oil consumption (after running-in period)	Max.	1% of fuel consumption, pertaining to full load
Sense of rotation		When viewing flywheel: left
Tappet clearance at 10–30 °C inlet/outlet	mm	0.10
Net weight		
2M41	Approx. kg	258
2M41Z		263
2L41C		303
Max. perm. inclination during continuous operation in direction		With and without oil sump
Operating side		30° ¹⁾
Exhaust air side		30° ¹⁾
Timing cover side		30° ¹⁾
Flywheel side		30° ¹⁾
Battery capacity	Min/max	12 V – 88/143 Ah/24 V – 55/110 Ah

¹⁾ Exceeding these limit values causes engine damage.

Engine oil capacities and dipstick equipment

Type	Oil sump	Engine oil capacity 2) liters	Mark on the dipstick
2L41C	With	7.5	C
2M41Z	Without	4.5	A
2M41	With	8.5	C
	Without	5.5	A

2) These values are approximations only. The max. mark on the dipstick is decisive in any case (see the chapter 7.8 *Check the oil level*, page 49).

4.2 Engine type plate

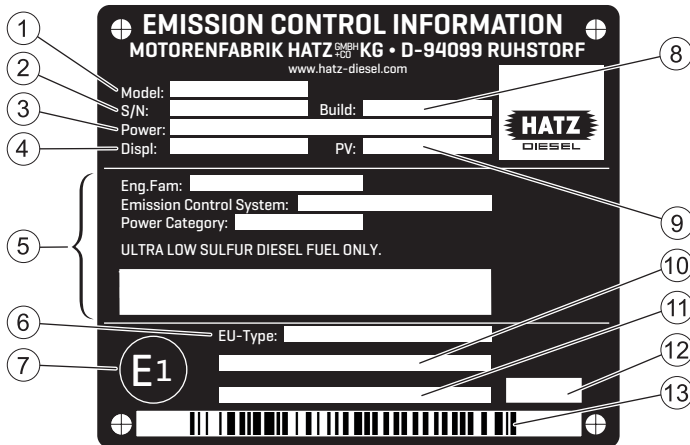

The layout of the EPA/CARB type plate depends on the engine application and is affixed to the crankcase or noise reduction capsule. It contains the following information:

1	Model designation of the engine
2	Engine serial number
3	Engine power (kW) at rated speed (rpm)
4	Displacement (liters)
5	Information for US emission certification (EPA/CARB)
6	EU type approval number
7	EU country of origin (Germany)
8	Model year (month/year)
9	Test specification for special settings

10	Engine family designation or exception code (EM) or transition code (TM) according to regulation (EU) 2016/1628
11	Additional specifications according to Regulation 2017/656 (exceptions) or "Separate shipment information"
12	Code for type plate variant
13	Barcode (engine serial number)

The type plate also defines the applicable emissions-related performance class of the engine.

The figure shows an EPA/CARB type plate.

A text that refers to the exhaust legislation and corresponds to the engine type is printed on the type plate (EPA or EPA and CARB).

Every engine is equipped with an additional unattached type plate. When the engine is built into a machine and the original type plate is not readily visible, the second unattached type plate must be affixed to the application in a position that is clearly visible for an average person.

The following data must always be specified in case of queries and for spare parts orders:

1	Model designation
2	Engine serial number
3	Rated speed (rpm)

Always install the engine appropriate for the intended application to fulfill the EPA and CARB exhaust requirements.

4.3 Physical operating conditions

Engine adjustment

The engine is normally adjusted to operate within the standard reference conditions stipulated in ISO 3046-1:

Parameter	Unit	Value
Intake air temperature	°C	+25
	K	298
Relative humidity	%	30
Air pressure (at approx. 100 meters above sea level)	kPa	100

NOTICE



If the machine is operated at high altitudes and high temperatures, adjustment of the engine setting may be necessary if the climatic conditions were not taken into account when the machine was ordered. If this is the case, please contact your nearest **HATZ service station**.

4.4 Engine oil

Oil quality

All oil brands that meet at least one of the following specifications are suitable:

- **ACEA – B3 / E4** or better
- **API – CF / CH-4** or better

If engine oils of a low quality standard are used, the oil change interval must be reduced from 250 to 150 or from 500 to 250 operating hours depending on the engine specification.

Oil viscosity

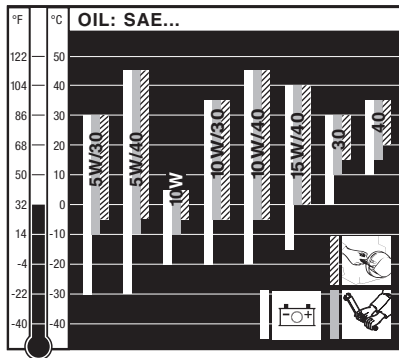

Choose the recommended viscosity based on the type of start (recoil, crankhandle or electric) and on the engine temperature at which the engine will be operated.

CAUTION

Engine damage from unsuitable engine oil.

Unsuitable engine oil considerably reduces engine service life. Only use engine oil that fulfills the specifications stipulated above.

4.5 Fuel

Fuel type

All types of diesel fuel that meet the minimum requirements of the following specifications are suitable:

- **Europe: EN 590**
- **UK: BS 2869 A1 / A2**
- **USA: ASTM D 975-09a 1-D S15 or 2-D S15**

CAUTION

Danger of engine damage from low quality fuel.

The use of fuel that does not meet the specifications can lead to engine damage.

- The use of fuel that does not meet specifications requires approval by Motorenfabrik HATZ (main plant).

CAUTION

Danger of malfunctions due to old fuel.

When diesel fuel is stored in a fuel tank or canister for lengthy periods, deposits may form on account of fuel aging. These deposits result in malfunctions due to clogged fuel filters and damage to the injection system.

- Perform the prescribed storage steps in machines that will be out of use for more than three months (see section *10.1 Storing the machine, page 95*).
- Only refuel with fresh diesel fuel such as can be obtained from filling stations.

Winter fuel

When outside temperatures drop below 0°C, use winter fuel or mix in petroleum in advance:

Lowest ambient temperature at start [°C]	Percentage of petroleum [%]for	
	Summer fuel	Winter fuel
0 to -10	20	-
-10 to -15	30	-
-15 to -20	50	20
-20 to -30	-	50

5 Engine design

Engine 2L41C

Encapsulated model "Silent Pack"

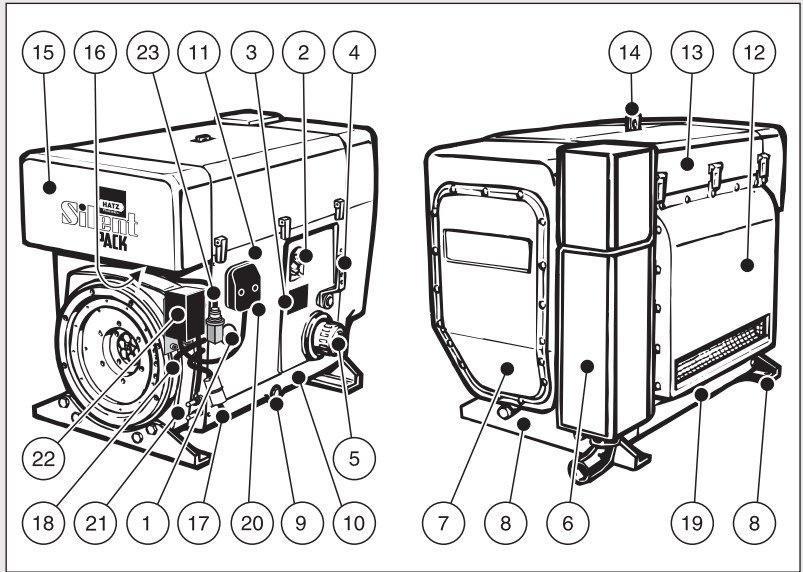

Pos.	Designation
1	Access cap for fuel feed pump
2	Oil filling opening and dipstick
3	Type plate
4	Speed control lever
5	Oil filter
6	Exhaust silencer (encapsulated)
7	Cover for air guide housing (access to cooling fan belt)
8	Engine brackets
9	Oil drain screw
10	Cover plate on operating side
11	Side wall
12	Exhaust air duct
13	Capsule hood
14	Retractable lifting eye, max. load 5000 N

Pos.	Designation
15	Capsule intake shaft
16	Intake opening for combustion air
17	Fuel feed line with fuel prefilter
18	Fuel return line
19	Cover plate on exhaust side
20	Central connector for electrical equipment
21	Battery connections
22	Powerbox
23	Electrical maintenance switch for air filter

Engine 2M41, 2M41Z

Standard model

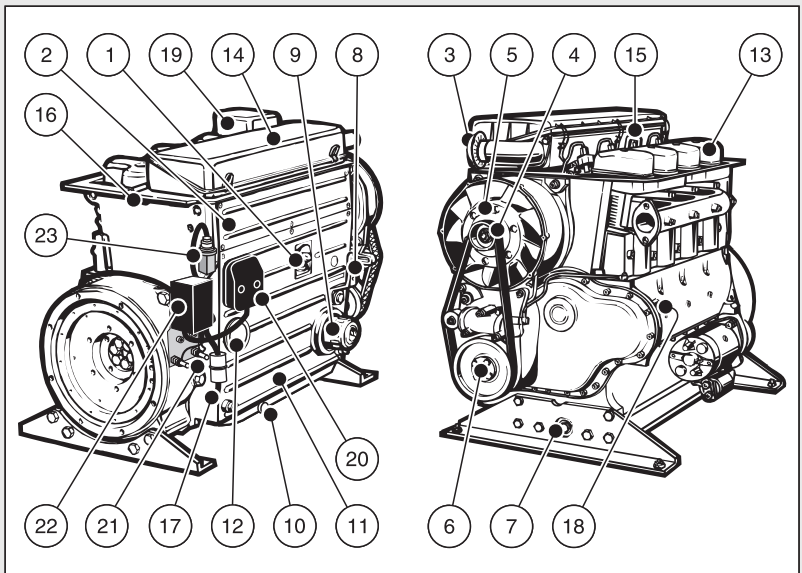







Pos.	Designation
1	Oil filling opening and dipstick
2	Side trim panel
3	Intake opening for combustion air
4	Cooling fan belt
5	Cooling fan with installed three phase alternator

Pos.	Designation
6	1/2-inch square socket for turning the engine
7	Oil drain screw
8	Speed control lever
9	Oil filter
10	Oil drain screw (on oil sump)
11	Cooling air guide for oil cooler
12	Access cap for fuel feed pump
13	Cylinder head cover
14	Air filter housing cover
15	Lifting eye, max. load 5000 N
16	Fuel return line
17	Fuel feed line with fuel prefilter
18	Type plate
19	Silencer
20	Central connector for electrical equipment
21	Battery connections
22	Powerbox
23	Electrical maintenance switch for air filter

6 Transport, assembly and commissioning

6.1 Transport

Safety notes

 WARNING	
	<p>Danger of injury from improper lifting and transport.</p> <p>Danger of crushing from falling or tipping of the engine.</p> <ul style="list-style-type: none"> ▪ Only use the lifting eye already mounted on the machine for lifting. ▪ Only use a suitable hoist with a sufficient carrying capacity. ▪ Do not remain under suspended loads.
 CAUTION	
	<p>Only use the lifting eye for transporting the engine.</p> <p>Do not use for lifting the entire machine.</p>
 CAUTION	
	<p>Danger of injury from overloading the body.</p> <p>Lifting the machine to transport it or to move it to another location can lead to injuries (of the back, for example).</p> <ul style="list-style-type: none"> ▪ Only lift the machine with a hoist.
NOTICE	
	<p>Danger of environmental damage from leaking fluid.</p> <p>If the machine is tilted, engine oil and fuel can run out.</p> <ul style="list-style-type: none"> ▪ Only transport the machine in an upright position.

Transport conditions

- When transporting the machine, follow the safety instructions.
- When transporting, follow the applicable safety and accident prevention regulations of the trade associations.
- After delivery, check the machine for completeness and transport damage.
- Only transport the machine when it is switched off and has cooled down.
- If you have questions on transporting the machine, please contact your nearest **HATZ service station**. For contact data, see chapter 1 *Impressum*, page 5 or www.hatz-diesel.com.

6.2 Installation notes

HATZ diesel engines are efficient, robust, and have a long service life. Therefore, they are usually installed in machines that are used for commercial purposes.

The machine manufacturer must follow the applicable regulations regarding machine safety – the engine is a part of a machine.

Depending on the use and installation of the engine, it may be necessary for the machine manufacturer and machine user to install safety equipment to prevent inappropriate use. Note the following:

- Parts of the exhaust gas system and the engine surface become hot during operation and may not be touched until they cool down after the engine is switched off.
- Incorrect cable connections and incorrect operation of the electrical equipment can lead to sparking and must be avoided.
- After the engine is installed in the machine, rotating parts must be protected against contact.
HATZ safety equipment is available for the belt drive of the cooling fan and alternator.
- Comply with all notices and warning labels on the engine and keep them in a legible condition. If a label should become detached or difficult to read, it must be replaced promptly. For this purpose, contact your nearest **HATZ service station**.
- Any improper modification of the engine will result in a loss of liability coverage for resulting damage.



Only regular maintenance, as specified in this manual, will maintain the operating readiness of the engine.

The **assembly instructions** contain important information on how to safely assemble the engine. They are available from any **Hatz service station**.

If you have any questions, please contact your nearest **HATZ service station** before commissioning the engine.

6.3 Preparations for commissioning



- Check the delivered parts for completeness, damage, and other noticeable issues.
- Ensure that the setup location is adequately ventilated.

 DANGER	
	<p>Danger to life from inhaling exhaust gases.</p> <p>Toxic engine exhaust gases can lead to loss of consciousness and even death in closed-off and poorly ventilated rooms.</p> <ul style="list-style-type: none"> ▪ Never operate the machine in closed-off or poorly ventilated rooms. ▪ Do not breathe in the exhaust gases.

6.4 Filling engine oil (first filling)

Engines are normally delivered without an engine oil filling.

Safety notes

 CAUTION	
 	<p>Danger of injury</p> <p>Prolonged contact with engine oil can lead to irritation of the skin.</p> <ul style="list-style-type: none"> ▪ Wear safety gloves. ▪ If there is contact with the skin, thoroughly wash the affected areas of the skin with soap and water.

CAUTION	
	<p>Danger of later engine damage.</p> <ul style="list-style-type: none"> ▪ Operating the engine with an oil level below the min. mark or above the max. mark can lead to engine damage. ▪ When checking the oil level, the engine must be horizontal and have been switched off for a few minutes.

Overview

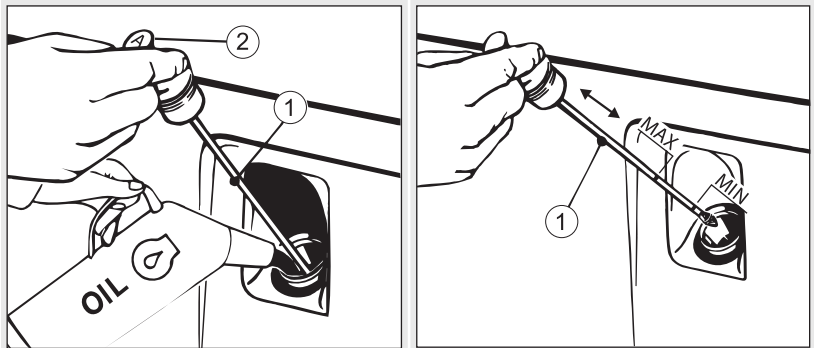

1	Dipstick
2	Code letter on the dipstick

Procedure

Step	Activity
1	Pull out the dipstick (1) and clean it.
2	Fill engine oil. For the specification and viscosity, see chapter 4.4 <i>Engine oil</i> , page 24. The code letter on the dipstick (2) indicates whether the engine is equipped with an oil sump or not . For the filling quantity, see chapter 4.1 <i>Engine information and filling quantities</i> , page 21.
3	Reinsert the dipstick.
4	Pull out the dipstick and check the oil level.
5	If required, top up the engine oil to the max. mark.
6	Reinsert the dipstick.

7 Operation and use

7.1 Safety notes

NOTICE



Comply with the safety chapter!

Follow the basic safety instructions in chapter 3 *Safety*, page 7.



WARNING



Danger of injury from damage and defects on the machine.

- Do not take the machine into service if damage has been localized and identified.
- Replace faulty components.



WARNING



Danger of injury from failure to follow the operating instructions and from performing unauthorized tasks on the machine.

- Define the responsibilities of the personnel taking the machine into service.
- Replace faulty machine parts immediately.
- Check the installation conditions when the machine is first taken into service and after the machine has been inactive for a lengthy period.

CAUTION

Danger of engine damage from low load operation.

Operating the engine at no load or at very low load for an extended period can impair the running characteristics of the engine.

- Make sure that the engine load is at least 15 %.
- Before switching off the engine following low load operation, briefly operate it at a considerably higher load.

7.2 Performing tests

Before starting

Before starting the engine, several tests need to be performed to ensure the machine is working properly.

Procedure

Step	Test
1	The machine is standing securely and on a level surface.
2	The installation location is adequately ventilated.
3	There is a sufficient amount of fuel in the fuel tank (see the chapter 4.5 <i>Fuel</i> , page 25).
4	There is a sufficient amount of engine oil in the engine housing (see the chapter 4.4 <i>Engine oil</i> , page 24).
5	For hand start: <ul style="list-style-type: none"> ▪ Crankhandle in functional condition. ▪ Sliding area between crankhandle and guide sleeve lightly greased.
6	No persons are located in the danger zone of the engine or machine.
7	All safety equipment is in place.

7.3 Start preparation

Procedure

Step	Activity
1	Before the first start and with an empty fuel system: <ul style="list-style-type: none"> ▪ Pump the fuel with the manual lever (see the chapter 7.3.1 <i>Pumping fuel with the manual lever</i>, page 34)

7.3.1 Pumping fuel with the manual lever

Requirements

Pre-pumping of fuel with the manual lever of the fuel feed pump is necessary in the following situations:

- Engine shuts down due to empty fuel tank
- at first filling of the fuel tank
- after changing the fuel filter

Overview

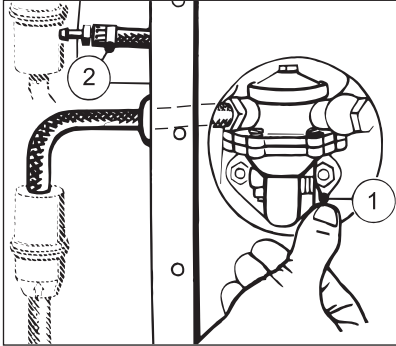

1	Manual lever (fuel feed pump)
2	Return line

Procedure

Step	Activity
1	Fill with fuel if necessary.
2	Remove the access cap for the fuel feed pump.
3	Actuate the manual lever (1) on the fuel feed pump until the fuel audibly flows back into the fuel tank through the return line (2).
4	Install the access cap again.

7.4 Setting the speed control

Overview

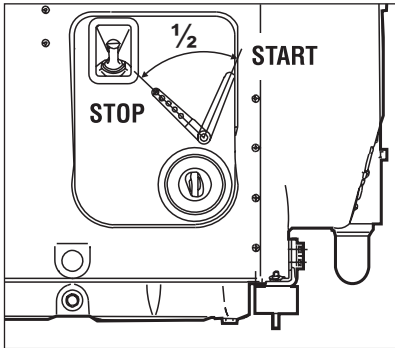

Procedure

Step	Activity
1	Depending on the situation, place the speed control lever in either the "1/2" or "Start" position.

NOTICE



A lower speed setting will cause less exhaust smoke when starting.

7.5 Starting the engine

Starting options

The standard equipment of the engine is an electric start mechanism. A hand starter can be installed as an option.

If possible, separate the engine from the machine being driven by uncoupling it. Always switch the machine into idle mode.

Safety notes





DANGER



Danger to life from inhaling exhaust gases.

Toxic engine exhaust gases can lead to loss of consciousness and even death in closed-off and poorly ventilated rooms.

- Never operate the machine in closed-off or poorly ventilated rooms.
- Do not breathe in the exhaust gases.

 CAUTION	
	<p>Danger of injury and danger of engine damage from the use of starting fluid.</p> <ul style="list-style-type: none"> ▪ Danger of injury during hand starting because the use of starting fluid can result in uncontrolled ignitions. ▪ Engine damage from uncontrolled ignition. ▪ Never use starting fluid.

7.5.1 Starting the engine with crankhandle

This chapter contains the following sections:

- **Preparations for cranking the engine:**

Adjust the continuous decompression.

- **Crank the engine:**

Crank the engine without compression (approx. 10-20 crank turns).

This lowers the resistance to rotation.

- **Preparations for starting the engine:**

Adjust the automatic decompression.

- **Start the engine:**

Cranking starts the cylinders one after the other and the decompression is automatically canceled.

Turning over the engine:

Safety note

CAUTION	
	<p>Danger of engine damage from decompression while the engine is running.</p> <ul style="list-style-type: none"> ▪ Do not operate the decompression lever while the engine is running.

Overview

Decompression lever

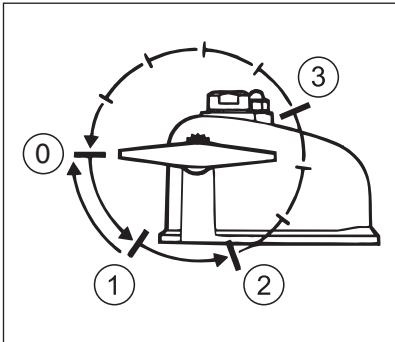

Attach the crank handle

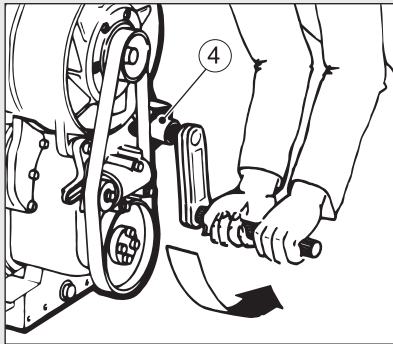

Position of operator

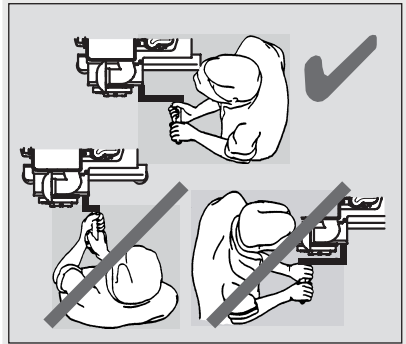

0 - 3	Positions of the decompression lever
4	Guide sleeve

Preparation

Step	Activity
1	Carry out start preparations (see the chapter 7.3 <i>Start preparation</i> , page 34).
2	Move the speed control lever to the "Start" position.
3	Turn the decompression level to position "1".

NOTICE

Only operate the decompression lever while the engine is at a standstill and observe the sense of rotation

- Only turn the decompression lever in the direction of the arrow.
- Exception: The lever can be turned directly back from position "1" to "0".
- Position "1" is the continuous decompression setting.

Procedure

Step	Activity
1	Insert the crankhandle into the guide sleeve (4).
2	Assume the correct position.
3	Grasp the handle bar with both hands.
4	Crank the engine until the crank resistance becomes markedly less.

Starting the engine**Safety note****CAUTION****Danger of injury from recoiling of the engine.**

- Use a crankhandle with a recoil damper.
- Hold the handle bar so that it cannot twist and quickly turn the crank so that continuous traction between the engine and crank is ensured.
- If recoil occurs due to cautious turning where the engine starts in the opposite sense of rotation under certain circumstances (smoke from the air filter), release the crankhandle immediately and stop the engine.
- To repeat the starting process, wait until the engine has stopped; only then recommence start preparations.

**CAUTION****Danger of injury if the crankhandle recoils or turns with the engine.**

- The use of crankhandles without recoil damping is not permissible within the European Union.

Overview

Numbering of the valves and cylinders from the fan side

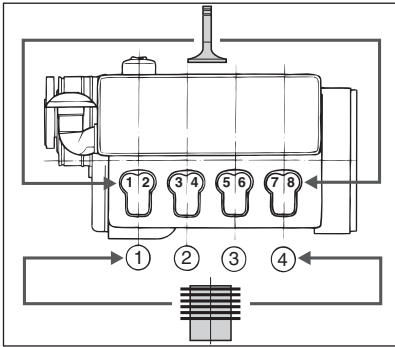

Crank handle

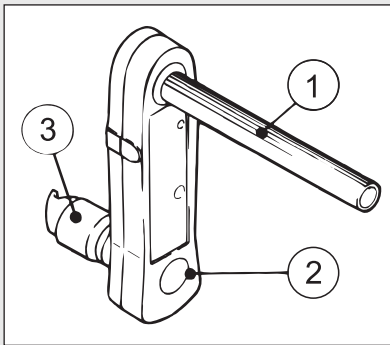

Attach the crank handle

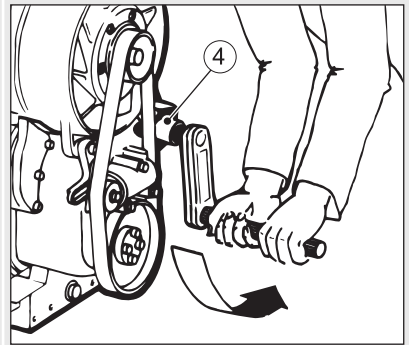

1	Handle bar
2	Crank arm
3	Drive dog
4	Guide sleeve

Preparation

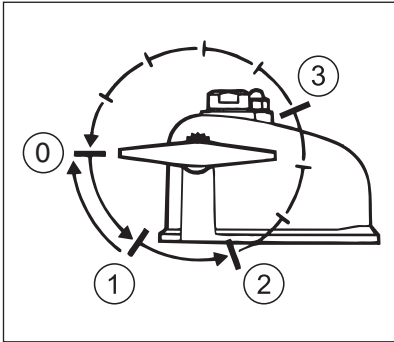

Step	Activity
1	Setting the decompression lever: <ul style="list-style-type: none"> ▪ Two cylinder engine 2M41. Turn the lever to position "2".

Starting the engine with a recoil-dampened crankhandle

Step	Activity
1	Assume the correct position.
2	Grasp the handle bar with both hands.
3	First turn the crankhandle slowly until the drive dog and the engagement mechanism of the crankhandle engage.
4	Turn the crankhandle forcefully with increasing speed. When the decompression lever engages in the "0" position (compression), the highest possible speed must be reached.
5	As soon as the engine starts, pull the crankhandle out of the guide sleeve.

NOTICE



If recoil occurs during the starting process, the crank arm/drive dog linkage releases via the handle bar due to the short reverse rotation.

Starting with a crankhandle without recoil damping

Only applies to engines **2M41** and **2M41Z**

Step	Activity
1	Assume the correct position.

Step	Activity
2	Grasp the handle bar (1) with both hands.
3	Slowly turn the crankhandle until the drive dog (3) engages.
4	Turn the crankhandle forcefully with increasing speed. When the decompression lever engages in the "0" position (compression), the highest possible speed must be reached.
5	As soon as the engine starts, pull the crankhandle out of the guide sleeve (4).

7.5.2 Starting the engine with a starter

Overview — HATZ instrument boxes

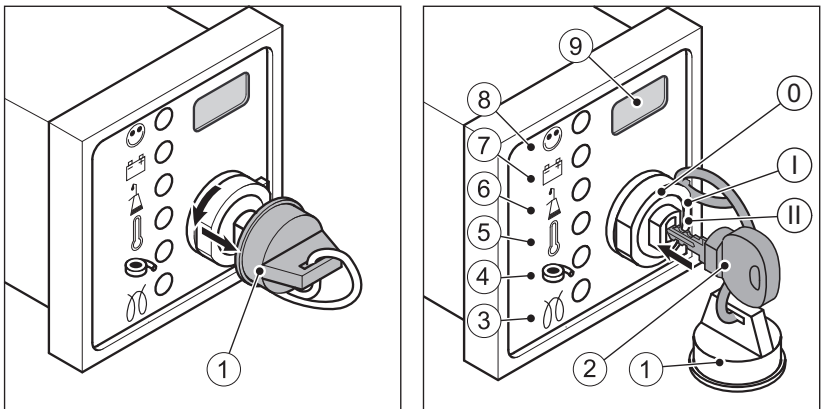







1	Protective cap
2	Starting key
3	Pre-glow display (option)
4	Air filter maintenance display
5	Engine temperature display (option)
6	Oil pressure display
7	Charge control
8	Operating display
9	Operating hours counter (option)
Ignition lock	
0	Off
I	Operation
II	Start

Indicators

The function of all indicators is checked when the starting key is turned. They flash or light up for different times. If there is a fault, the applicable indicator does not go out after the engine start or it lights up again during operation.

Explanation of symbols

Symbol	Meaning
	Operating indicator Lights up during operation when there is no engine fault.
	Charge control Fault in the alternator or alternator charging circuit. The battery is no longer charged. Eliminate the fault immediately.
	Oil pressure display Engine oil pressure too low. Danger of engine damage. Stop the engine immediately and check the oil level (see section 7.8 <i>Check the oil level, page 49</i>). Contact HATZ Service if the oil level is correct.
	Engine temperature display Engine temperature is impermissibly high. Danger of engine damage. Switch off the engine immediately! For details of troubleshooting, see section 9.1 <i>Troubleshooting, page 87</i> .
	Air filter maintenance display This display lights up if the air filter is dirty. Clean or replace the filter cartridge immediately. For more information, see chapter 8.2.11 <i>Maintaining the dry air filter, page 71</i> .
	Pre-glow display Lights at temperatures below 0 °C. Start the engine when the indicator has gone out.

Procedure – Starting the engine with a starter

NOTICE



- Start for max. 30 seconds. If the engine is still not running after that, turn the starting key back to position "0" and eliminate the cause (see chapter 9.1 *Troubleshooting, page 87*).
- Turn the starting key to position "0" every time you want to start the engine.
- The anti repeat device in the ignition lock makes it impossible for the starter to engage while the engine is running and become damaged.

NOTICE

The starter protection module prevents the starter from engaging while the engine is running and becoming damaged.

- The starter protection module is required when the user cannot detect at the ignition lock if the engine is still running or is already at a standstill.
- In models equipped with a starter protection module, the starting key must be kept in the 0 position for at least 8 seconds before another start is possible after the engine is switched off.

Step	Activity
1	Check the speed adjustment (see chapter 7.4 <i>Setting the speed control</i> , page 36).
2	Remove the protective cap (1) from the ignition lock.
3	Insert the starting key all the way and turn to position "I". When the pre glow display (3) lights up, wait until it goes out then continue with step 4.
4	Turn the starting key to position "II".
5	As soon as the engine is running, release the starting key. <ul style="list-style-type: none"> ▪ The starting key springs back to position "I" and remains in this position during operation. ▪ The charge control (7) and oil pressure display (6) go out. ▪ Operating display (8) lights up and signals there is no engine fault.

NOTICE

- In case of irregularities, switch off the engine immediately.
- Identify the fault and eliminate it.
- For details of troubleshooting, see chapter 9.1 *Troubleshooting*, page 87.

Automatic electrical shutoff (option)

The identifying feature of the electrical automatic shutoff is brief flashing of all indicator lamps after the starting key is turned to position "I".

NOTICE

- If the engine stops again immediately after starting, or stops independently during operation, this is an indication that a monitoring element of the automatic shutoff has activated.
- Remedy the fault before making further starting attempts (see chapter 9.1 *Troubleshooting*, page 87).
- The automatic shutoff is **no** protection against low oil level. This means that the oil level must be checked every 8 - 15 operating hours despite the automatic shutoff. (see section 7.8 *Check the oil level*, page 49).

Procedure when faults occur

Step	Activity
1	Check the indicators (5-7). After the engine comes to a standstill, the fault will continue to be displayed by the indicator for approx. another 2 minutes.
2	Then the electrical equipment switches off automatically.
3	Set the starting key to position "0".
4	Turn the starting key back to position "I". The fault display lights up again. Remedy the fault before making further starting attempts (see chapter 9.1 <i>Troubleshooting</i> , page 87). The indicator then goes out at the next start.

7.6 Switching off the engine**Safety notes****CAUTION****Danger of injury from unauthorized access.**

There is a danger of injury if unauthorized persons handle the machine.

- Protect the crankhandle and starting key against unauthorized access upon breaks in operation or after completing work.

CAUTION**Danger of engine damage.**

- Never stop the engine on the decompression lever.

CAUTION

Protect the ignition lock against dirt and moisture.

- With the starting key pulled out, seal the ignition lock with the protective cap.

Methods of switching off the engine

The engine can be switched off in different ways depending on how it is equipped:

- Speed control lever (mechanical)
- Starting key (electrical)

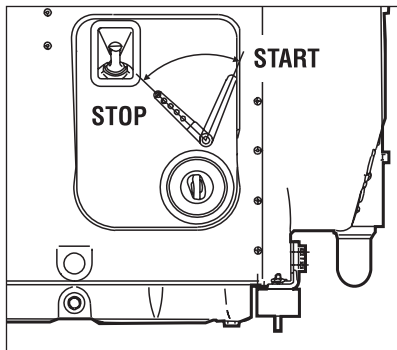
7.6.1 Switching off the engine (mechanical)**Overview****Procedure**

Step	Activity
1	Move the speed controller lever to the "STOP" position. The engine switches off.
2	Additional step for engines with a starter: <ul style="list-style-type: none"> ▪ Turn the starting key to position "0". All indicator lamps go out.

NOTICE

Engines with an automatic switch-off can also be switched off by turning the starting key back to position "0".

7.6.2 Switching off the engine (electrical)

Overview — HATZ instrument boxes

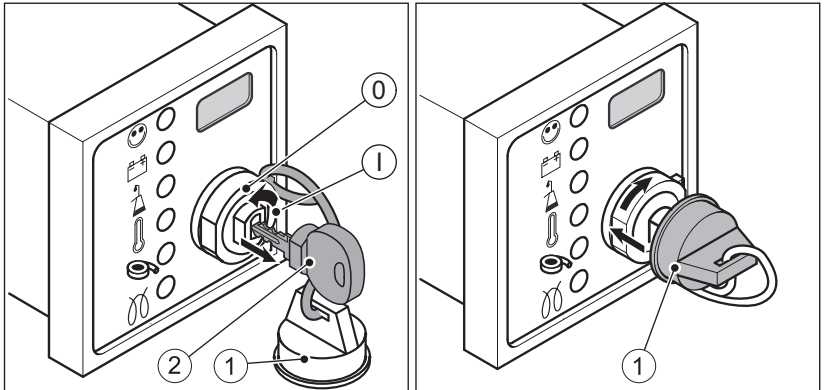

1	Protective cap
2	Starting key
Ignition lock	
0	Off
I	Operation

Procedure

Step	Activity
1	Turn the starting key (2) to position "0". The engine switches off. All indicator lamps go out.
2	Remove the starting key.
3	Seal the ignition lock with the protective cap (1).

NOTICE







Danger of exhaustive battery discharge.

- When the machine is switched off, always turn the starting key to position "0" or else the battery may become fully discharged.

7.7 Refueling





This diesel engine is intended for installation in a machine or for assembly with other machines to form a machine and does not have its own fuel tank. Follow the instructions from the manufacturer and comply with the following safety information.

Safety notes

 DANGER	
 	<p>Fire hazard from fuel.</p> <p>Leaked or spilled fuel can ignite on hot engine parts and cause serious burn injuries.</p> <ul style="list-style-type: none"> ▪ Only refuel when the engine is switched off. ▪ Never refuel in the vicinity of open flames or sparks that can cause ignition. ▪ Do not smoke. ▪ Do not spill fuel.
 CAUTION	
	<p>Danger of environmental damage from spilled fuel.</p> <p>Do not overfill the fuel tank and do not spill fuel.</p> <ul style="list-style-type: none"> ▪ Collect any leaking fuel and dispose of it according to local environmental regulations.
CAUTION	
	<p>Engine damage from using low quality fuel.</p> <p>The use of fuel that does not meet the specifications can lead to engine damage.</p> <ul style="list-style-type: none"> ▪ Only use the fuel specified in chapter 4.5 <i>Fuel</i>, page 25. ▪ The use of fuel that does not meet specifications requires approval by Motorenfabrik HATZ (main plant).

7.8 Check the oil level

Safety notes

⚠ CAUTION	
 	<p>Danger of burns.</p> <p>There is a danger of burns when working on a hot engine.</p> <ul style="list-style-type: none"> Wear safety gloves.
⚠ CAUTION	
 	<p>Danger of injury</p> <p>Prolonged contact with engine oil can lead to irritation of the skin.</p> <ul style="list-style-type: none"> Wear safety gloves. If there is contact with the skin, thoroughly wash the affected areas of the skin with soap and water.
CAUTION	
	<p>Danger of later engine damage.</p> <ul style="list-style-type: none"> Operating the engine with an oil level below the min. mark or above the max. mark can lead to engine damage. When checking the oil level, the engine must be horizontal and have been switched off for a few minutes.

Overview — Checking oil level/adding oil

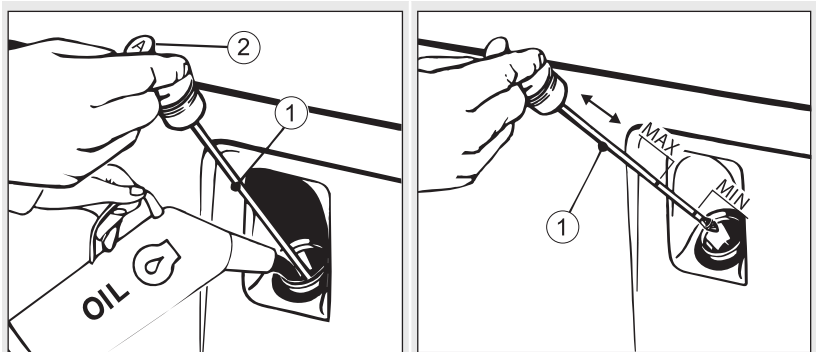

1 Dipstick

2	Code letter on the dipstick
---	-----------------------------



Procedure — Checking oil level/adding oil

Step	Activity
1	Switch off the engine and wait several minutes for the engine oil to collect in the crankcase. Engine must be level.
2	Remove contamination on the engine in the area of the dipstick (1).
3	Pull out the dipstick and clean it.
4	Reinsert the dipstick.
5	Pull out the dipstick and check the oil level.
6	If the oil level is close to the min. mark, add engine oil to the max. mark. For the specification and viscosity, see chapter <i>4.4 Engine oil</i> , page 24.
7	Reinsert the dipstick.

8 Maintenance

8.1 General maintenance instructions

Safety notes

 WARNING	
	<p>Danger of injury from failure to follow the operating instructions and from performing unauthorized tasks on the machine.</p> <ul style="list-style-type: none"> ▪ Follow all instructions. ▪ Do not perform activities for which no qualification is available. Contact properly trained personnel if necessary.

NOTICE	
	<p>Comply with the safety chapter!</p> <p>Follow the basic safety instructions in chapter 3 <i>Safety</i>, page 7.</p>

- Maintenance tasks may only be performed by trained personnel.
- Accident prevention measures must be in accordance with the local accident prevention regulations.
- Perform setting and maintenance work at the specified intervals.
- Replace faulty machine parts as soon as possible.
- Always wear personal protection equipment.
- Only use fully functional tools.
- Installation of unsuitable spare parts can lead to problems. We cannot accept responsibility for direct damage or secondary damage that results from this. We therefore recommend the use of **Hatz original spare parts**.
- Closely adhere to the maintenance conditions prescribed in this manual.
- Only make changes to the machine in agreement with the manufacturer.
- Only perform maintenance work when the engine is stopped.
- Protect start-up devices (crank handle, recoil start or starting key) from unauthorized access.
- For engines with an electric starter: Disconnect the negative battery terminal before carrying out maintenance work.
- Adhere to legal regulations when handling and disposing of used oil, filters, and cleaning agents.
- After completing maintenance work, check that all tools, bolts, aids, and other objects are removed from the machine, and that all safety equipment has been replaced.

- Before starting, ensure that no persons are located in the danger zone of the engine or machine.



Performance of maintenance work

The entire machine is designed to be maintenance friendly. Parts that require maintenance are easily accessible.

- Perform maintenance work faithfully at the specified intervals to prevent premature wear of the machine.
- Follow the notice and warning labels on the machine.
- Always retighten screw connections loosened during maintenance work.
- After the necessary maintenance and repair work is completed, perform a function test (test run).
- For maintenance work that is not listed and described in the maintenance documentation, please contact your nearest **HATZ service station**.

8.2 Maintenance work

Safety note

 CAUTION	
	<p>Danger of injury if maintenance instructions are not followed.</p> <ul style="list-style-type: none"> ▪ Only perform maintenance when the engine is switched off. ▪ Protect start-up devices (crank handle, recoil start or starting key) from unauthorized access. ▪ For engines with a starter: Disconnect the negative battery terminal. ▪ When the maintenance work has been completed, ensure that all tools are removed from the machine.

8.2.1 Maintenance notice label

NOTICE	
	<p>Depending on the engine type, one of the maintenance plans shown below is supplied with the engine.</p> <ul style="list-style-type: none"> ▪ It should be mounted on the engine or machine in a clearly visible location. ▪ The maintenance intervals specified on the maintenance plan must be adhered to (see chapter 8.2.2 <i>Maintenance plan, page 54</i>)

2M41 and 2M41Z without oil sump

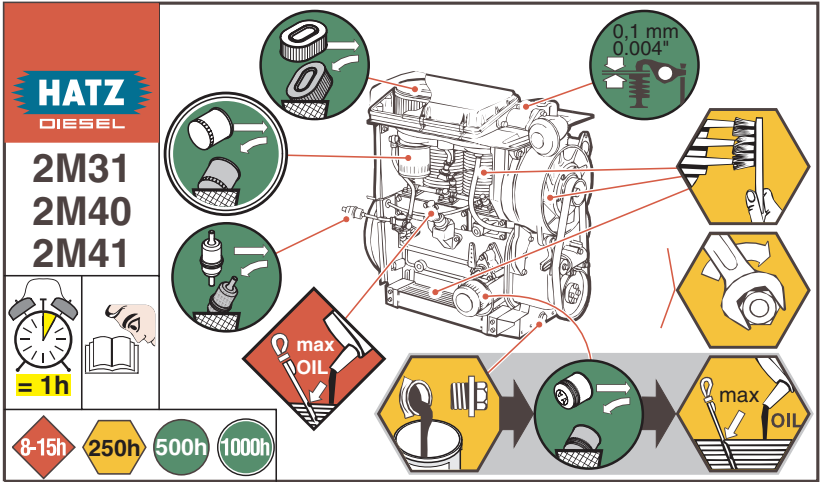

2M41 and 2M41Z with oil sump

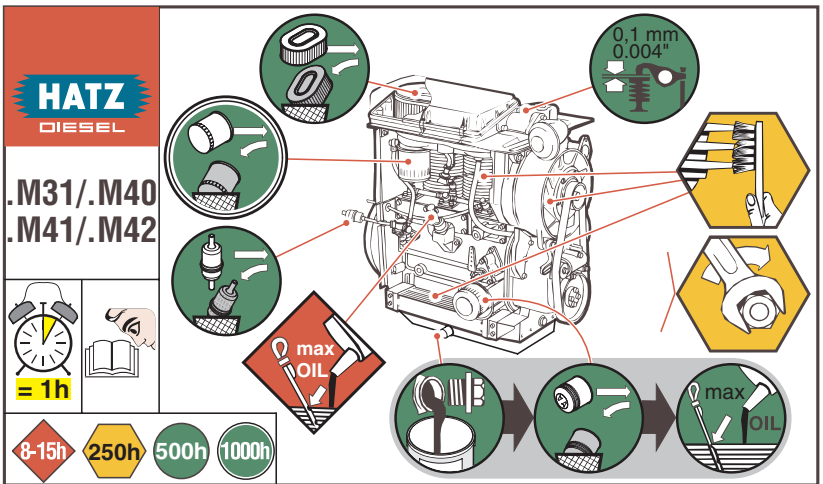

2L41C

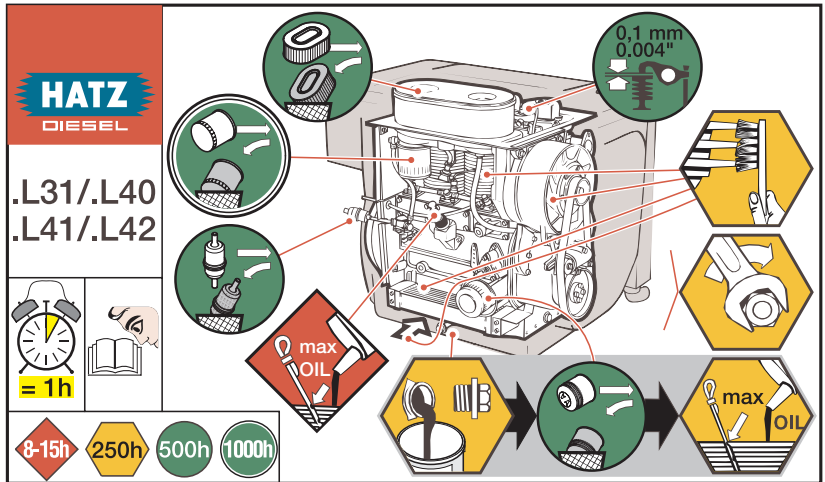

8.2.2 Maintenance plan

In new and generally overhauled engines, after 25 operating hours:



- Change the engine oil
- Check the tappet clearance and adjust if necessary
- Check the screw connections (do not retighten the screws for attaching the cylinder head)

In case of a low number of operating hours, change the engine oil no later than every 12 months, regardless of the actual number of operating hours.

The degree of contamination of the fuel, the care with which refueling is performed and the soiling on the inside of the fuel tank are decisive in determining the change interval of the fuel **pre**filter and the main fuel filter.



Symbol	Maintenance interval	Maintenance step/check	Chapter
	Every 8–15 operating hours or every day before starting	Check the oil level.	<i>7.8 Check the oil level, page 49</i>
		Check the intake area of the combustion air.	<i>8.2.3 Checking the intake area of the combustion air, page 56</i>
		Check the cooling air area.	<i>8.2.4 Checking the cooling air area, page 59</i>

Symbol	Maintenance interval	Maintenance step/check	Chapter
		Visual check of the condition of the crank handle (handle bar, crank arm, drive dog) If necessary, lightly grease gliding area between crank handle and guide sleeve.	–
	Every 250 operating hours	Change the engine oil (2M41 and 2M41Z without oil sump, 2L41C in general).	<i>8.2.5 Change the engine oil, page 60</i>
		Check the poly v belt.	<i>8.2.6 Checking the poly v belt, page 62</i>
		Clean the cooling fan, cooling fins and oil cooler.	<i>8.2.7 Cleaning the cooling fan, cooling fins and oil cooler, page 63</i>
		Check the screw connections.	<i>8.2.8 Checking the screw connections, page 67</i>
		Clean the screen insert in the exhaust pipe.	<i>8.2.9 Cleaning the screen insert in the exhaust pipe (additional equipment), page 67</i>
		Check the fuel pre filter for contamination and change it if necessary.	<i>8.2.10 Changing the fuel prefilter, page 69</i>
		Check the air filter maintenance indicator.	<i>8.2.16 Checking that the air filter maintenance indicator is working properly, page 81</i>

Symbol	Maintenance interval	Maintenance step/check	Chapter
	Every 500 operating hours	Change the fuel pre filter.	<i>8.2.10 Changing the fuel prefilter, page 69</i>
		Maintain the dry air filter. Change the filter cartridge.	<i>8.2.11 Maintaining the dry air filter, page 71</i>
		Check and set the tappet clearance.	<i>8.2.13 Check and set the tappet clearance, page 75</i>
		Change the engine oil (2M41 and 2M41Z with oil sump).	<i>8.2.5 Change the engine oil, page 60</i>
		Change the oil filter.	<i>8.2.14 Changing the oil filter, page 78</i>
	Every 1000 operating hours	Change the main fuel filter.	<i>8.2.15 Change the main fuel filter, page 79</i>
---	Every 2000 operating hours	Renew the gaskets in the belt tensioner or the complete belt tensioner. (To be carried out by a trained specialist)	
		Renew the poly v belt.	<i>8.2.17 Renewing the poly v belt and checking the function of the switch-off unit, page 83</i>

8.2.3 Checking the intake area of the combustion air

Safety notes

 CAUTION	
 	<p>Danger of burns.</p> <p>There is a danger of burns when working on a hot engine.</p> <ul style="list-style-type: none"> ▪ Let the engine cool. ▪ Wear safety gloves.

NOTICE

In case of heavy contamination, shorten the maintenance intervals accordingly (see chapter 8.2.2 *Maintenance plan*, page 54).

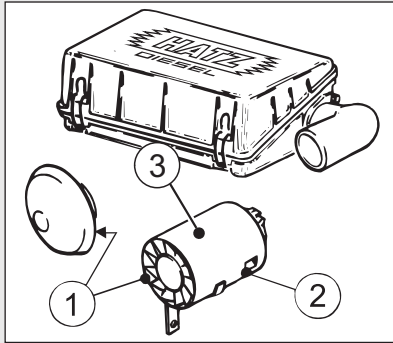
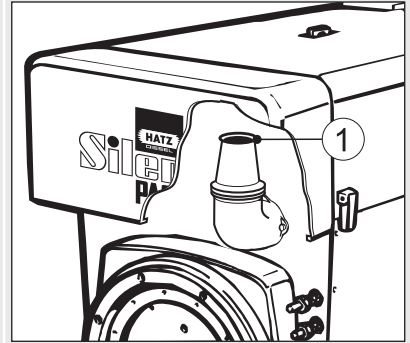
Overview**2M41 and 2M41Z****2L41C**

Pos.	Designation
1	Intake opening for combustion air
2	Dust outlet opening
3	Cyclone (option)

Procedure

Step	Activity
1	Check the intake opening (1) for coarse contamination such as leaves, heavy dust deposits, etc., and clean if necessary.
2	Check that the dust outlet opening (2) at the bottom of the cyclone pre-cleaner is clear.
3	If the dirt contamination is oily, remove the cyclone (3) and clean it.

Air filter maintenance display

Electrical display

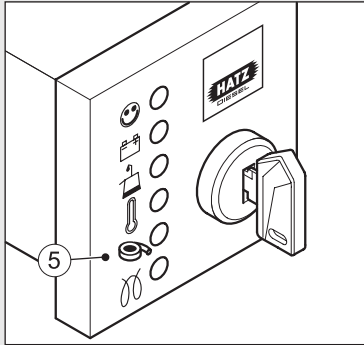

Mechanical display

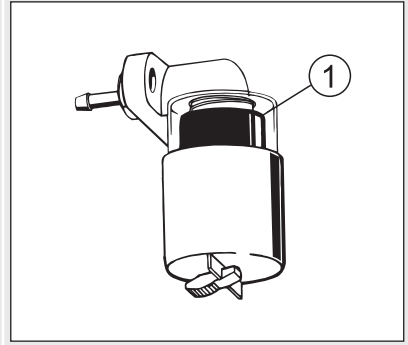







Pos.	Designation
1	Red field
5	Air filter maintenance display

Procedure

Step	Activity
For the electrical air filter maintenance display:	
1	Briefly let the engine run at maximum speed and watch for the indicator (5) to light up for a short period – depending on the version. If it lights up, this indicates that maintenance work is required on the air filter (see the chapter 8.2.11 <i>Maintaining the dry air filter</i> , page 71).
With mechanical air filter maintenance display:	
1	Briefly let the engine run at maximum speed and watch for the visible red field (1) in the mechanical air filter maintenance display. The visible red field (1) indicates that maintenance work is required on the air filter (see the chapter 8.2.11 <i>Maintaining the dry air filter</i> , page 71).

8.2.4 Checking the cooling air area

Safety notes





 CAUTION	
	<p>Danger of burns.</p> <p>There is a danger of burns when working on a hot engine.</p> <ul style="list-style-type: none"> ▪ Let the engine cool before maintenance.
 CAUTION	
 	<p>Danger of injury.</p> <p>When working with compressed air, foreign bodies may fly into your eyes.</p> <ul style="list-style-type: none"> ▪ Wear safety goggles. ▪ Never direct the compressed air jet toward people or toward yourself.
CAUTION	
	<p>Danger of engine damage from overheating.</p> <p>The engine temperature display (option) lights up as soon as the engine becomes impermissibly hot.</p> <ul style="list-style-type: none"> ▪ Switch off the engine immediately and eliminate the cause.
NOTICE	
	<p>In case of heavy contamination, shorten the maintenance intervals accordingly (see chapter 8.2.2 <i>Maintenance plan</i>, page 54).</p>

Procedure

Step	Activity
1	Check the supply and exhaust air areas for coarse contamination such as leaves, heavy dust deposits, etc., and clean if necessary (see chapter 8.2.7 <i>Cleaning the cooling fan, cooling fins and oil cooler</i> , page 63).

8.2.5 Change the engine oil

Safety notes

 CAUTION	
 	<p>Danger of burns.</p> <p>When working on the engine there is a danger of burns from hot oil.</p> <ul style="list-style-type: none"> ▪ Wear personal protective equipment (gloves). ▪ Collect the used oil and dispose of it according to local environmental regulations.
NOTICE	
	<ul style="list-style-type: none"> ▪ The engine must be level. ▪ The engine must be switched off. ▪ Only drain engine oil while it is warm.

Overview

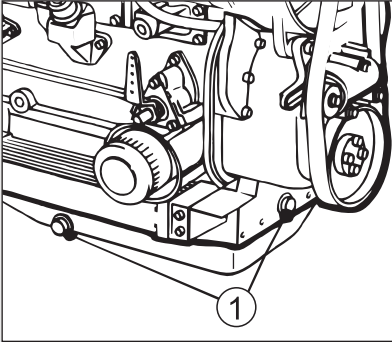
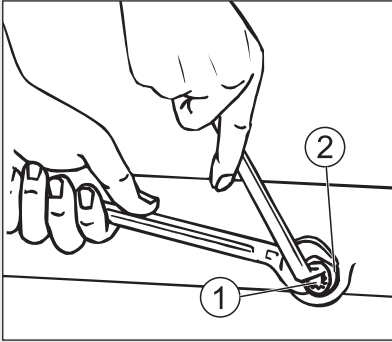
M41	L41
	
1	Oil drain screw
2	Drain pipe

Draining the oil

Step	Activity
1	Unscrew the oil drain screw (1) and drain the oil entirely. When unscrewing the oil drain screw (1) on engines of type 2L41C , ensure that the drain pipe (2) is not loosened. Hold it with an open-end wrench.
2	Screw in the cleaned oil drain screw (1) with the new gasket and tighten.

Overview — Checking oil level/adding oil

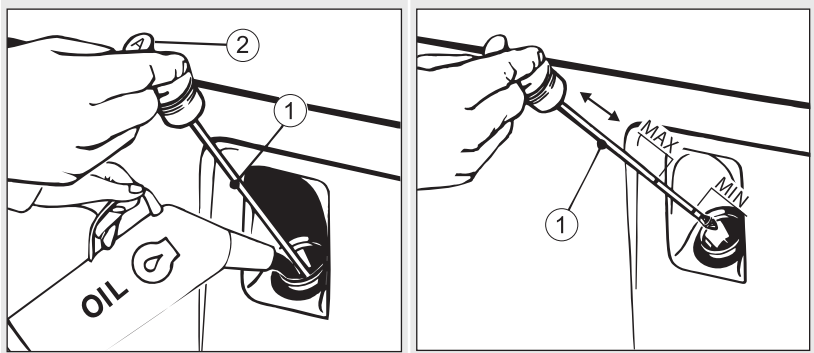





1	Dipstick
2	Code letter on the dipstick

Procedure — Adding oil

Step	Activity
1	Add engine oil to the max. mark on the dipstick (1). <ul style="list-style-type: none"> For the specification and viscosity, see chapter <i>4.4 Engine oil</i>, page 24. The code letter on the dipstick (2) indicates whether the engine is equipped with an oil sump or not (see chapter <i>4 Technical data</i>, page 21).
2	Reinsert the dipstick (1).
3	After a short test run, check the oil level and correct it if necessary (see the chapter <i>7.8 Check the oil level</i> , page 49).

8.2.6 Checking the poly v belt

Safety notes

 CAUTION	
	<p>Danger of burns.</p> <p>There is a danger of burns when working on a hot engine.</p> <ul style="list-style-type: none"> Let the engine cool before maintenance.
 CAUTION	
	<p>Damage from inadequate engine cooling.</p> <p>Only operate the engine when all covers are installed.</p>

Preparation

Step	Activity
1	On encapsulated engines , unscrew the cover of the air guide housing (see chapter 5 <i>Engine design</i> , page 26).
1	On engines without a capsule , unscrew the belt guard (see chapter 5 <i>Engine design</i> , page 26).

Overview

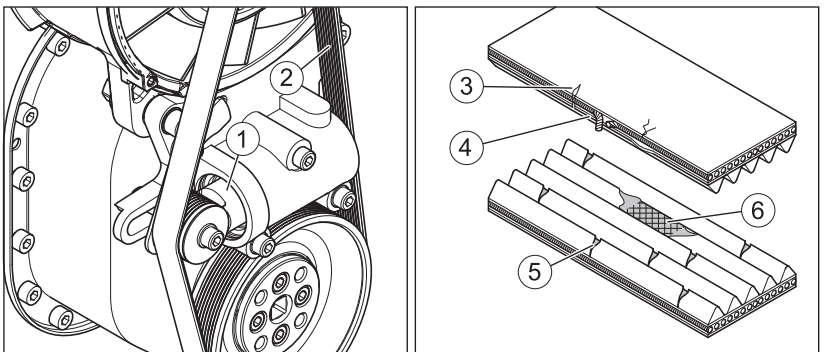

1	Belt tensioner
2	Poly v belt

Damage on the poly v belt

3	Transverse cracks on the rear
4	Fraying on the edges

5	Transverse cracks in multiple ribs
6	Broken ribs

Procedure

Step	Activity
1	Check the belt tensioner (1) for leaks. If the belt tensioner is oily, contact HATZ service .
2	<p>Check the poly v belt (2) for the following damage:</p> <ul style="list-style-type: none"> ▪ Transverse cracks on the rear of the belt. ▪ Fraying on the side. ▪ Accumulation of dirt between the ribs. ▪ Oily dirt contamination. ▪ Transverse cracks in multiple ribs. ▪ Broken ribs. <p>If one or more of these instances of damage are present, replace the poly v belt (see chapter 8.2.17 <i>Renewing the poly v belt and checking the function of the switch-off unit, page 83</i>).</p>
3	Refit the air guide housing cover and belt guard.

8.2.7 Cleaning the cooling fan, cooling fins and oil cooler

Safety notes



DANGER



Danger of explosion from flammable cleaning agents.

Cleaning with benzene is an explosion hazard. It is highly flammable, can become electrostatically charged, and can generate an explosive gas/air mixture.

- Use halogen-free, cold cleaners with a high flashpoint for cleaning.
- Comply with manufacturer's instructions.



CAUTION



Danger of burns.

There is a danger of burns when working on a hot engine.

- Let the engine cool before maintenance.

**CAUTION****Danger of injury.**

When working with compressed air, foreign bodies may fly into your eyes.



- Wear safety goggles.
- Never direct the compressed air jet toward people or toward yourself.

CAUTION**Danger of engine damage from overheating.**

The engine temperature display (option) lights up as soon as the engine becomes impermissibly hot.

- Switch off the engine immediately and eliminate the cause.

CAUTION**Danger of damage to the machine from incorrect engine cleaning.**

- Let the engine fully cool down before cleaning.
- Do not spray components of the electrical equipment with a water jet or high pressure jet during cleaning.
- Do not use gasoline or acid-based cleaning agents.

**CAUTION****Damage from inadequate engine cooling.**

Only operate the engine when all covers are installed.

NOTICE

In case of heavy contamination, shorten the maintenance intervals accordingly (see chapter 8.2.2 *Maintenance plan*, page 54).

Overview — Preparatory activities

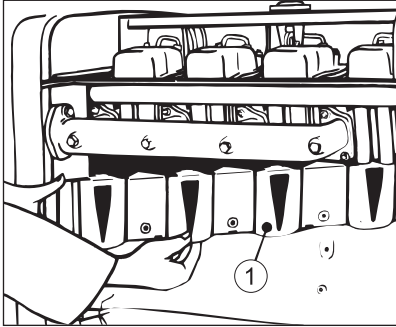

1	Baffle plate
---	--------------

Preparation — Cleaning

Step	Activity
1	<p>On encapsulated engines unscrew the following: (see chapter 5 <i>Engine design</i>, page 26)</p> <ul style="list-style-type: none"> ▪ Hood ▪ Side panel ▪ Cover plate on operating side ▪ Air outlet duct for cooling air ▪ Cover plate on air outlet side
1	<p>Remove the following on engines without a capsule:</p> <ul style="list-style-type: none"> ▪ Side trim panel ▪ Cooling air guide for lubrication oil cooler
2	Unscrew the baffle plate (1)

Overview — Cleaning

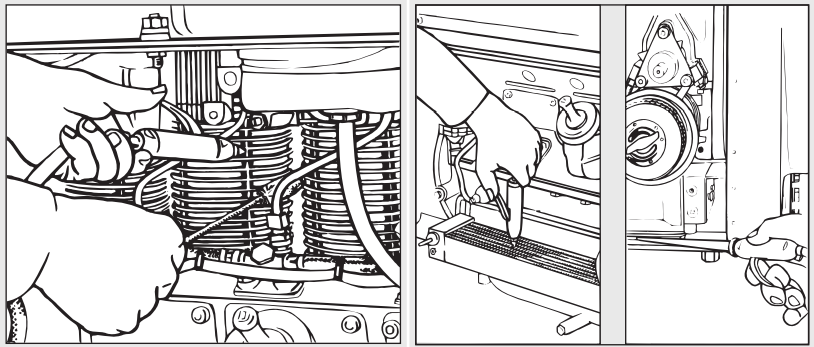

Procedure — Cleaning

Step	Activity
Cleaning in case of dry dirt contamination	
1	Clean the cooling fan, cylinder head and cylinder with a suitable brush.
2	Blow out the entire cooling air area with compressed air.
3	Blow out the oil cooler with compressed air only. <i>NOTE:</i> <ul style="list-style-type: none"> ▪ Do not place the compressed air gun against the sensitive radiator fins.
4	On encapsulated engines, also clean the area between the floor plate and crankcase.
5	Mount the capsule and air guide parts again.
Cleaning of wet or oily dirt contamination	
1	Disconnect the negative battery terminal.
2	Manually clean the alternator and regulator.
3	Cover the alternator with the installed regulator and do not spray directly.
4	Spray the entire area with a suitable cleaning solution according to manufacturer instructions and then clean off with a jet of water. Do not spray components of the electrical equipment with a water jet or high pressure jet during cleaning.
5	Blow dry the engine with compressed air.

Step	Activity
6	Determine the cause of the oil contamination and have leaks corrected by the HATZ service station .
7	Mount the capsule and air guide parts again.
8	Let the engine run warm to prevent rust formation.

8.2.8 Checking the screw connections

Safety note



NOTICE	
	<ul style="list-style-type: none"> Do not retighten the screws for attaching the cylinder head. The adjustment screws on the speed governor and the injection system are secured with locking varnish and are not permitted to be tightened or adjusted. Only retighten loose screw connections. Screw connections can be secured with thread locking adhesive or tightened to a defined torque. Retightening tight screw connections can cause damage.

Procedure

Step	Activity
1	Check the condition of all screw connections and ensure that they are tight (for exceptions, see note).
2	Tighten any lose screw connections.

8.2.9 Cleaning the screen insert in the exhaust pipe (additional equipment)

Safety notes

 CAUTION	
	<p>Danger of burns.</p> <p>There is a danger of burns when working on a hot engine.</p> <ul style="list-style-type: none"> Let the engine cool before maintenance.

**CAUTION****Danger of injury**

There is a danger of injury when performing cleaning work at the exhaust screen.



- Wear safety gloves.

NOTICE

Operation of the engine for a lengthy period without a load or with only a small load can result in premature deposits on the screen insert.

Shorten the maintenance interval accordingly.

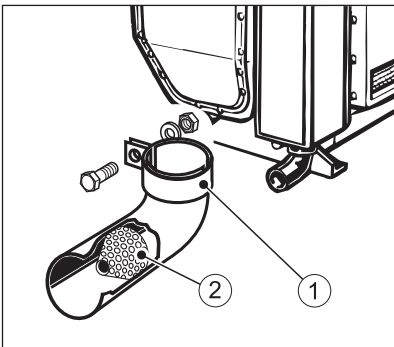
Overview

1	Pipe clamp
2	Screen insert

Procedure

Step	Activity
1	Release the pipe clamp (1) and remove it with the exhaust pipe.
2	Remove deposits on the screen insert (2).
3	Check the screen insert for cracks or breakage, and replace if necessary.

8.2.10 Changing the fuel prefilter

 DANGER	
 	<p>Fire hazard from fuel.</p> <p>Leaked or spilled fuel can ignite on hot engine parts and cause serious burn injuries.</p> <ul style="list-style-type: none"> ▪ Never refuel in the vicinity of open flames or sparks that can cause ignition. ▪ Do not smoke. ▪ Do not spill fuel.
 CAUTION	
 	<p>Danger of injury</p> <p>Repeated contact with diesel fuel can cause chapped and cracked skin.</p> <ul style="list-style-type: none"> ▪ Wear safety gloves.
 CAUTION	
	<p>Danger of environmental damage from spilled fuel.</p> <p>When the filter is removed, a small amount of fuel is drained as well.</p> <ul style="list-style-type: none"> ▪ Collect any escaping fuel and dispose of it according to local environmental regulations.
CAUTION	
	<p>Dirt particles can damage the injection system.</p> <ul style="list-style-type: none"> ▪ Maintain clean conditions to ensure dirt does not enter the fuel line.

Overview

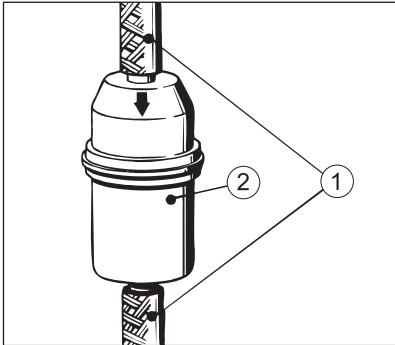

1	Fuel lines
2	Fuel prefilter

Procedure

Step	Activity
1	Place a suitable container under the filter to collect emerging fuel.
2	Close the fuel feed line.
3	Pull the fuel lines (1) off of the fuel prefilter (2) on both sides.
4	Dispose of the old filter in accordance with local environmental regulations.
5	Insert a new fuel prefilter. Note the following: <ul style="list-style-type: none"> ▪ Arrow for flow direction ▪ Position of the fuel tank: HIGH or LOW ▪ Installation position/flow-through direction should be as vertical as possible
6	Open the fuel feed line.
7	To simplify the starting procedure, it is recommended that you pre-pump the fuel using the manual lever at the fuel feed pump until you hear fuel flow back through the return line into the fuel tank (see the chapter <i>7.3.1 Pumping fuel with the manual lever</i> , page 34).
8	Perform a leak tightness test by activating the manual lever.
9	After completion, insert the access cover to the fuel feed pump back in the side wall.

8.2.11 Maintaining the dry air filter

NOTICE



- Immediately clean the filter cartridge if the maintenance display appears at maximum speed.
- Renew the filter cartridge after a use period of 500 operating hours.

Overview of engine 2L41C

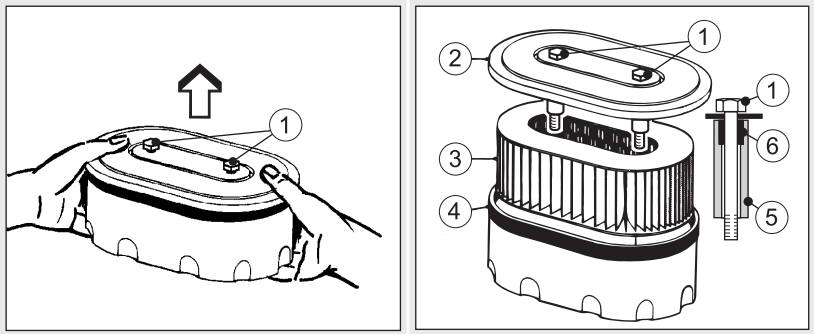

Pos.	Designation
1	Screw
2	Cover
3	Filter cartridge
4	Air filter housing
5	Spacer
6	Bushing

Remove the air filter cartridge - engine 2L41C

Step	Activity
1	Remove the capsule hood.
2	Remove adherent dirt in the area of the air filter housing (4).
3	Only loosen the screws (1) to the point where you can lift off the complete air filter housing (4).
4	Cover the opening in the intake pipe to prevent ingress of dirt and other foreign bodies.
6	Open the air filter housing (4).
7	Take out the filter cartridge (3).

Step	Activity
8	Clean the air filter housing (4) and cover (2).
9	Renew the bushing (6) if the spacer (5) is loose. <ul style="list-style-type: none"> ▪ The spacer (5) is connected with the screw (1) by the elastic bushing (6) to ensure that it cannot fall into the intake pipe during disassembly and assembly.

Overview of the engines 2M41 and 2M41Z

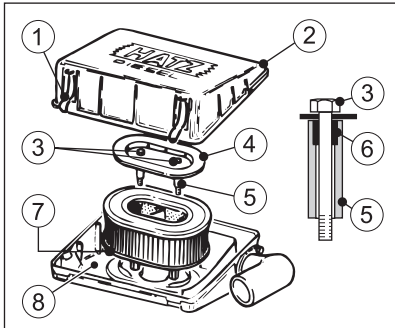





Pos.	Designation
1	Clamp
2	Air filter housing cover
3	Screw
4	Filter cover
5	Spacer
6	Bushing
7	Filter cartridge
8	Air filter housing

Remove the air filter cartridge - engines 2M41 and 2M41Z

Step	Activity
1	Release the clamps (1) and remove the cover of the air filter housing (2).
2	Remove adherent dirt in the air filter area.
3	Only loosen the screws (3) to the point where the filter cover (4) can be removed with the filter cartridge (7).
4	Cover the opening in the intake pipe to prevent ingress of dirt and other foreign bodies.
5	Clean the air filter housing cover (2), filter cover (4) and air filter housing (8).
6	<p>Renew the bushing (6) if the spacer (5) is loose.</p> <ul style="list-style-type: none"> The spacer (5) is connected with the screw (3) by the elastic bushing (6) to ensure that it cannot fall into the intake pipe during disassembly and assembly.

8.2.12 Checking and cleaning the air filter cartridge

Safety notes

 CAUTION	
 	<p>Danger of injury.</p> <p>When working with compressed air, foreign bodies may fly into your eyes.</p> <ul style="list-style-type: none"> Wear safety goggles. Never direct the compressed air jet toward people or toward yourself.
NOTICE	
	<ul style="list-style-type: none"> The pressure must not exceed 5 bar. A distance of approx. 150 mm must be maintained between the filter cartridge and the compressed air gun. The filter cartridge may not be washed out or beaten out. Even minor damage in the areas of the sealing surface, filter paper or filter cartridge makes it impossible to reuse the filter cartridge.

Overview — Checking/cleaning the air filter cartridge

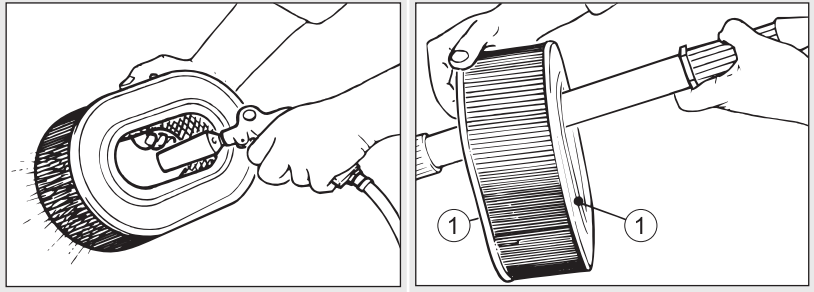

1 Sealing surface

Step	Activity
------	----------

Dry contamination

- | | |
|---|--|
| 1 | Blow out the filter cartridge with dry compressed air from the inside to the outside until dust no longer emerges. |
| 2 | Check the sealing surfaces (2) of the filter cartridge for damage. |
| 3 | Check the filter cartridge for cracks in the filter paper and other damage by holding it against the light at a slant or letting light from a lamp shine through it. |
| 4 | Replace the filter cartridge if necessary (see note). |

Moist or oily contamination

- | | |
|---|-----------------------------|
| 1 | Renew the filter cartridge. |
|---|-----------------------------|

Mechanical air filter maintenance display

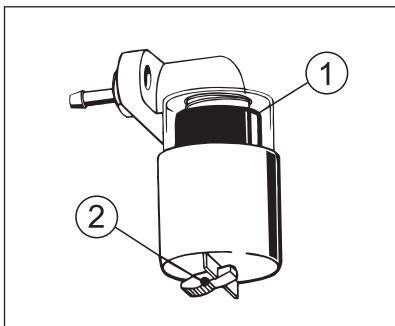

1 Red field

2 Reset button

Procedure — Mounting the air filter cartridge

Step	Activity
1	When assembling, mount the parts individually one after the other to make sure they are correctly seated and to ensure leak tightness.
2	After the filter is mounted, unlock the visible red field (1) in the maintenance display by pressing the reset button (2).

8.2.13 Check and set the tappet clearance**Safety notes****CAUTION****Danger of burns.**

There is a danger of burns when working on a hot engine. Only perform the settings while the engine is cold (10-30°C).

- Let the engine cool.

**CAUTION****Damage from inadequate engine cooling.**

Only operate the engine when all covers are installed.

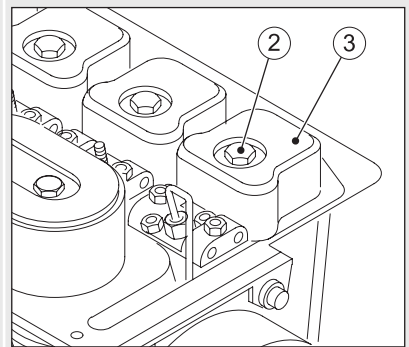
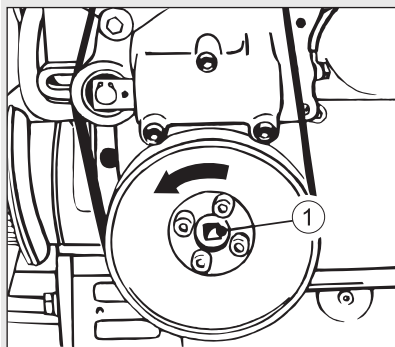
Overview — Preparatory activities

1	Square opening
2	Hexagon nut
3	Cylinder head cover

Preparation — Adjusting the tappet clearance

Step	Activity
1	On encapsulated engines, remove the hood of the capsule (see chapter 5 <i>Engine design</i> , page 26).
2	Remove the hex nut (2) and remove the cylinder head cover (3).
3	Remove the air guide housing cover (see chapter 5 <i>Engine design</i> , page 26) and belt guard.
4	Insert the ratchet or T-piece 1/2" with the required extension (1) into the square opening.

NOTICE



Turn the engine in the sense of rotation.

Anti-clockwise in both cases - flywheel side or timing cover side.

Numbering of the valves and cylinders from the fan side

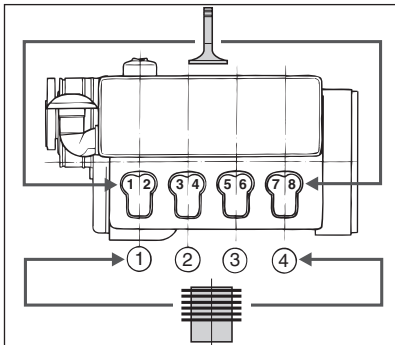

Setting method for two cylinder engine

Step	Activity
1	Set the valve of the 1st cylinder – fan side – to overlap (outlet valve not yet closed, intake valve begins to open).
2	Turn the crankshaft by 180° in the sense of rotation and check the valves of the 2nd cylinder.
3	Continue turning the crankshaft by 180° in the sense of rotation and check the valves of the first cylinder.

Overview — Adjusting the tappet clearance

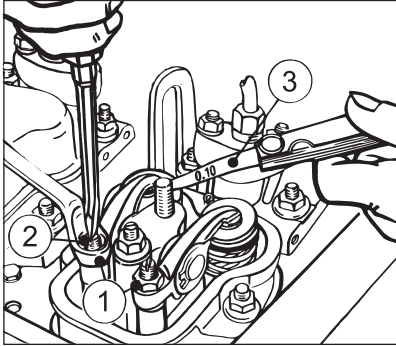



1	Hexagon nut
2	Adjusting screw
3	Feeler gage

Procedure — Adjusting the tappet clearance

Step	Activity
1	Check the tappet clearance with the feeler gauge (3). For the setting, see the chapter 4 <i>Technical data</i> , page 21
2	If the tappet clearance needs to be corrected: <ul style="list-style-type: none"> ▪ Release the hex nut (1). ▪ Turn the adjustment screw (2) so the feeler gauge (3) can be pulled through with a barely perceptible resistance after the hex nut (1) is tightened again.
3	Repeat the above procedure for the entire valve area, taking special care to use the described adjustment method.
4	Mount the cylinder head cover again: <ul style="list-style-type: none"> ▪ Always renew the gaskets. ▪ Use the fixing nuts for the cylinder head cover no more than twice before renewing them. ▪ Tightening torque: 10 Nm.
5	Mount all covers. <i>NOTE:</i> <ul style="list-style-type: none"> ▪ Under no circumstances is the engine permitted to be operated if not all covers are mounted.
6	After a brief trial run, check the cylinder head cover for tightness.

8.2.14 Changing the oil filter

Safety note

 CAUTION	
 	<p>Danger of burns.</p> <p>When working on the engine there is a danger of burns from hot oil.</p> <ul style="list-style-type: none"> ▪ Wear personal protective equipment (gloves). ▪ Collect the used oil and dispose of it according to local environmental regulations.

Overview

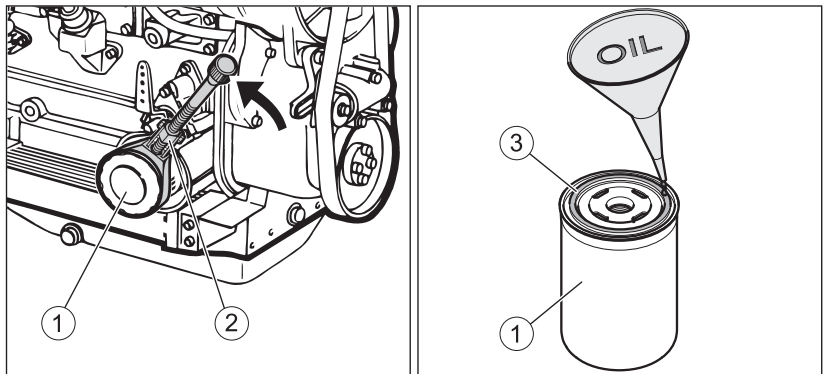

1	Oil filter
2	Strap wrench
3	Gasket

Procedure

Step	Activity
1	Release the oil filter (1) with a strap wrench (2) and quickly unscrew it or pull it out. <ul style="list-style-type: none"> ▪ HATZ order no. for strap wrench: 620 307 01.
2	Dispose of the old filter in accordance with local environmental regulations.
3	Wipe spilled engine oil out of the oil baffle.
4	Lightly oil the gasket (3) of the new oil filter.
5	Screw in the oil filter and tighten it by hand.

Step	Activity
6	<p>Add engine oil to the max. mark on the dipstick.</p> <ul style="list-style-type: none"> For the specification and viscosity, see chapter 4.4 <i>Engine oil</i>, page 24. The mark on the dipstick indicates whether the engine is equipped with an oil sump or not (see chapter 4.1 <i>Engine information and filling quantities</i>, page 22).
7	Reinsert the dipstick.
8	Check the oil level after a short test run and correct if necessary.
9	Check the oil filter for tightness and retighten by hand if necessary.

8.2.15 Change the main fuel filter

Safety notes

 DANGER	
 	<p>Fire hazard from fuel</p> <p>Leaked or spilled fuel can ignite on hot engine parts and cause serious burn injuries.</p> <ul style="list-style-type: none"> Do not spill fuel. No open flames when working on the fuel system. Do not smoke.
 CAUTION	
 	<p>Danger of injury</p> <p>Repeated contact with diesel fuel can cause chapped and cracked skin.</p> <ul style="list-style-type: none"> Wear safety gloves.
 CAUTION	
	<p>Danger of environmental damage from spilled fuel.</p> <p>When the filter is removed, a small amount of fuel is drained as well.</p> <ul style="list-style-type: none"> Collect any escaping fuel and dispose of it according to local environmental regulations.

CAUTION**Dirt particles can damage the injection system.**

- Maintain clean conditions to ensure dirt does not enter the fuel line.

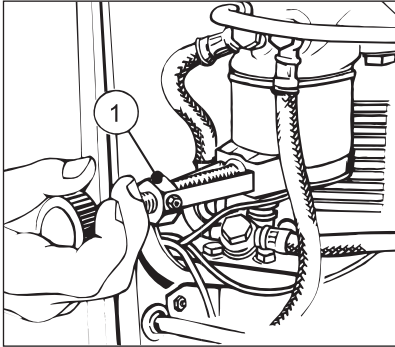
Overview

Pos.	Designation
1	Strap wrench (HATZ order no.: 620 307 01)

Procedure

Step	Activity
1	On encapsulated engines: <ul style="list-style-type: none"> ▪ Lift off the capsule hood (see the chapter 5 <i>Engine design</i>, page 26).
	On engines without a capsule: <ul style="list-style-type: none"> ▪ Remove the side trim panel (see the chapter 5 <i>Engine design</i>, page 26).
2	Place a suitable container under the filter to collect emerging fuel.
3	Close the fuel feed line.
4	Slide on the strap wrench (1) and unscrew the fuel filter counter-clockwise.
5	Dispose of the old filter in accordance with local environmental regulations.
6	Lightly oil the gasket of the new fuel filter.
7	Mount the fuel filter and tighten it by hand .

Step	Activity
8	Open the fuel feed line.
9	To simplify the starting procedure, it is recommended that you pre-pump the fuel using the manual lever at the fuel feed pump until you hear fuel flow back through the return line into the fuel tank (see the chapter 7.3.1 <i>Pumping fuel with the manual lever</i> , page 34).
10	Perform a leak tightness test by activating the manual lever.
11	After completion, insert the access cover to the fuel feed pump back in the side wall.
12	Mount the capsule and air guide parts again.

8.2.16 Checking that the air filter maintenance indicator is working properly

Overview

Electrical
air filter maintenance display

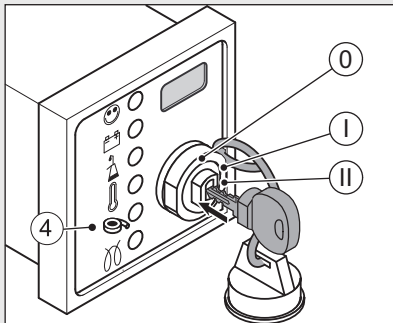

Mechanical
air filter maintenance display

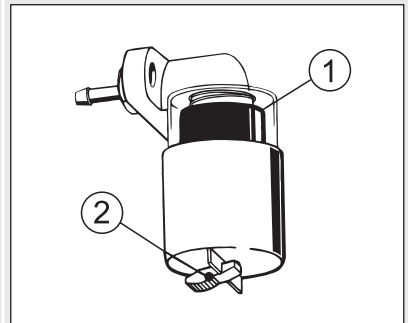

Hose of air intake pipe

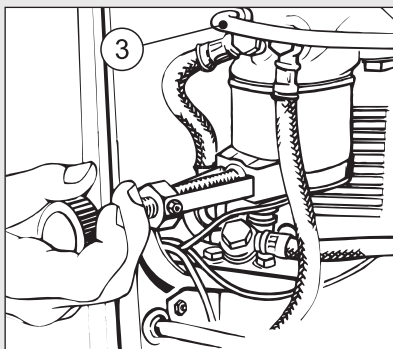

Pos.	Designation
1	Red field
2	Reset button
3	Hose
4	Air filter maintenance display
Ignition lock	
0	Off
I	Operation
II	Start

Procedure

Step	Activity
1	Remove the capsule hood and the side panel trim (see the chapter <i>5 Engine design, page 26</i>).
2	Turn the starting key to position I.
3	Pull the hose (3) off of the exhaust manifold.
Electrical air filter maintenance display	
4	Generate a vacuum by sucking forcefully at the hose end. The indicator (5) lights up.
5	If there is no reaction, check the following: <ul style="list-style-type: none"> ▪ Electrical part; cable connections, etc. ▪ Indicator ▪ Function of the maintenance switch.
Mechanical air filter maintenance display	
4	Generate a vacuum by sucking forcefully at the hose end. The red field (1) engages.
5	After the function test, unlock the red field (1) by pressing the reset button (2).
After the function test	
6	Replace the faulty parts.
7	Reattach the hose (3) of the exhaust manifold.
8	Mount the capsule and air guide parts again.

8.2.17 Renewing the poly v belt and checking the function of the switch-off unit

NOTICE



When changing the belt:

- Always check the function of the switch-off unit. The switch-off pin must emerge by spring force, or else the machine will not switch off automatically if the belt tears.
- If the grooves are broken off or bent, renew the damaged pulley.
- To be absolutely sure that you order the right poly v belt – in terms of the length – it is recommended that you measure the diameter of the fan-side pulley and use this as the basis for your selection.

Belt types

Because of the different diameters of the fan-side pulleys, in combination with different engine types and versions, various lengths of poly v belts are used.

Type and engine version	ID number	Belt length mm	Fan pulley Ø mm
2L41C	502 031 00	920	72
All remaining types and versions	501 415 00	910	64

Overview — Removing the poly v-belt

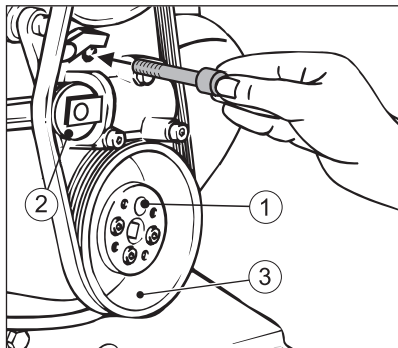

1	Cylinder screw
2	Tension pulley
3	Pulley

Procedure — Removing the poly v belt

Step	Activity
1	Unscrew one cylinder screw (1) from the pulley (3).
2	Push back the tension pulley (2) and lock it using the cylinder screw (1).
3	Unscrew the pulley (3).
4	Check the pulley (3) for broken or bent grooves.
5	Remove the poly v belt.

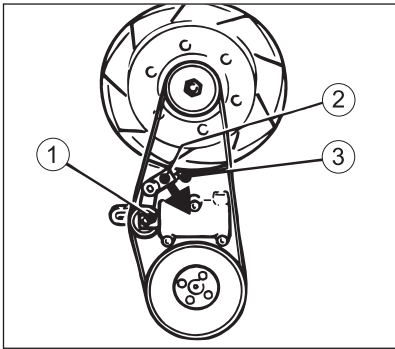
Overview — Checking the function of the switch-off unit of the belt monitoring system

1	Tension pulley
2	Angle lever
3	Switch-off pin

Procedure — Checking the function of the switch-off unit of the belt monitoring system

Step	Activity
1	<p>Release the piston with the tension pulley (1) by removing the cylinder screw.</p> <ul style="list-style-type: none"> ▪ The piston with the tension pulley is pushed out of the housing by spring pressure. ▪ The angle lever (2) turns downward and releases the switch-off pin (3). ▪ The switch-off pin (3) must emerge by spring force, or else the machine will not switch off automatically if the belt tears.
2	If there is no reaction, please contact the nearest HATZ service station .

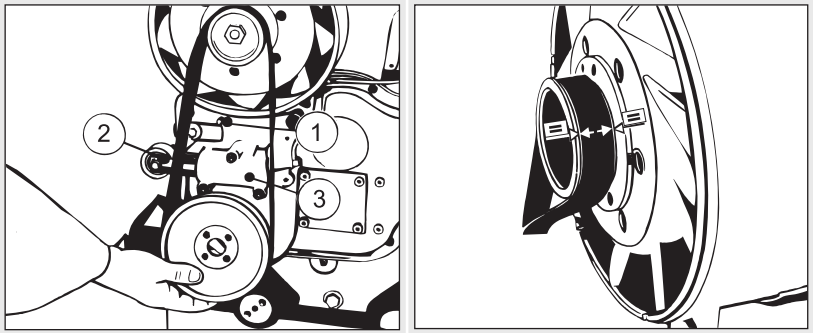
Overview — Mounting the poly v-belt

1	Switch-off pin
2	Tension pulley
3	Housing

Procedure — Mounting the poly v belt

Step	Activity
1	Slide in the switch-off pin (1).
2	Slide the piston with the tension pulley (2) into the housing (3) and lock it using the cylinder screw.
3	Position the poly v belt centrally on the pulley of the fan wheel, the tension pulley (2) and the pulley at the bottom.

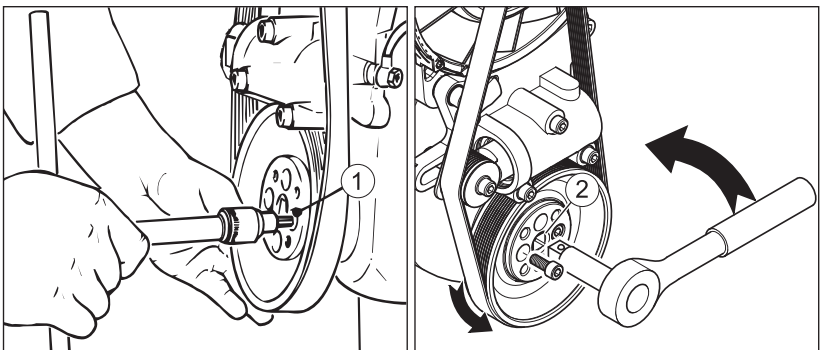
Overview — Centering the pulley

1	Cylinder screw
2	Square opening

Procedure — Centering the pulley

Step	Activity
1	Lightly secure the pulley with a cylinder screw (1) without placing the pulley fully on the centering.
2	Insert the ratchet or T-piece 1/2" with the required extension into the square opening (2).
3	Turn the pulley until a further cylinder screw can be fitted.
4	Insert the remaining cylinder screws and tighten all screws.

9 Faults

9.1 Troubleshooting

General troubleshooting notes

If the cases listed below have been worked through but the fault continues to persist, please contact your nearest **Hatz service station**.

The engine does not start or does not start immediately, but it can be turned with the starter.

Possible causes	Remedy	Chapter
Move the speed control lever to the "STOP" position.	Depending on the possibility or requirement, place the lever in either the 1/2 start or max. START position. The lever must be fixed in this position.	<i>7.4 Setting the speed control, page 36</i>
No fuel at the injection pump.	Refuel.	<i>7.7 Refueling, page 48</i>
	Activate the manual lever of the fuel pump.	<i>7.3 Start preparation, page 34</i>
	Systematically check the entire fuel supply. If this does not yield results:	
	▪ Check the feed line to the engine.	
	▪ Check the fuel prefilter.	<i>8.2.10 Changing the fuel prefilter, page 69</i>
	▪ Check the main fuel filter.	<i>8.2.15 Change the main fuel filter, page 79</i>
	▪ Check the function of the feed pump.	
After every extended period of disuse, if you experience difficulties starting the engine that can be eliminated by activating the feed pump for a lengthy period, check that the fuel system is correctly sized.		<i>6.2 Installation notes, page 30</i>
Injection nozzle is not functional.	Contact Hatz service.	

Possible causes	Remedy	Chapter
Poly v belt torn.	Renew the poly v belt.	<i>8.2.17 Renewing the poly v belt and checking the function of the switch-off unit, page 83</i>
Insufficient compression:		
<ul style="list-style-type: none"> ▪ Wrong tappet clearance. 	Check the tappet clearance and adjust if necessary.	<i>8.2.13 Check and set the tappet clearance, page 75</i>
<ul style="list-style-type: none"> ▪ Cylinder and/or piston ring wear. 	Contact Hatz service.	
<ul style="list-style-type: none"> ▪ Faulty automatic de-compression. 	Contact Hatz service.	

At low temperatures (engine does not start)

Possible causes	Remedy	Chapter
Faulty pre glow system.	Contact HATZ Service.	
Fuel gelled due to insufficient cold resistance.	Check whether the fuel that emerges from the fuel feed line is clear and not cloudy. If the fuel has gelled, either thaw the engine or drain the entire fuel supply system. Fill with a temperature-resistant fuel mixture.	<i>4.5 Fuel, page 25</i> <i>8.2.10 Changing the fuel prefilter, page 69</i> <i>8.2.15 Change the main fuel filter, page 79</i>
Oil is too viscous and causes a too low starter speed.	Change the engine oil and oil filter. Add engine oil with a suitable viscosity class.	<i>8.2.5 Change the engine oil, page 60</i>
Insufficiently charged battery.	Check the battery and contact the service center if necessary.	<i>3.2.4 Electrical equipment, page 18</i>
Machine is not uncoupled.	If possible, separate the engine from the machine by uncoupling it.	

The starter does not switch on and the engine does not turn.

Possible causes	Remedy	Chapter
Irregularities in the electrical equipment:		
Battery and/or other cable connections are incorrectly connected.	Check the electrical equipment and its components or contact Hatz service.	<i>3.2.4 Electrical equipment, page 18</i>
Cable connections are loose and/or oxidized.		
Battery is faulty and/or not loaded.		
Faulty starter.		
Faulty relay, monitoring elements, etc.		

The engine starts, but does not continue running after the starter is switched off.

Possible causes	Remedy	Chapter
The speed control lever is not sufficiently set in the Start direction.	Set the lever to the Start position.	<i>7.4 Setting the speed control, page 36</i>
Machine is not uncoupled.	If possible, separate the engine from the machine by uncoupling it.	
Fuel prefilter is clogged.	Change the fuel prefilter.	<i>8.2.10 Changing the fuel prefilter, page 69</i>
Main fuel filter is clogged.	Change the main fuel filter.	<i>8.2.15 Change the main fuel filter, page 79</i>
Fuel supply is interrupted.	Systematically check the entire fuel supply.	
Stop signal from monitoring elements that are associated with the automatic switch-off (optional):		
▪ No oil pressure.	Check the oil level.	<i>7.8 Check the oil level, page 49</i>
▪ Faulty three phase alternator.	Contact Hatz service.	

Possible causes	Remedy	Chapter
<ul style="list-style-type: none"> Engine temperature too high. 	Check the cooling air guides for contamination or other impairments.	8.2.7 <i>Cleaning the cooling fan, cooling fins and oil cooler, page 63</i>

Engine switches off spontaneously during operation.

Possible causes	Remedy	Chapter
The tank ran out of fuel during operation.	Fill with fuel.	7.7 <i>Refueling, page 48</i>
Fuel prefilter or main fuel filter is clogged.	Change the fuel filter.	8.2.10 <i>Changing the fuel prefilter, page 69</i> 8.2.15 <i>Change the main fuel filter, page 79</i>
Poly v belt torn.	Renew the poly v belt.	8.2.17 <i>Renewing the poly v belt and checking the function of the switch-off unit, page 83</i>
Mechanical faults.	Contact Hatz service.	

With automatic electrical switch-off mechanism (option)

Possible causes	Remedy	Chapter
Stop signal of monitoring elements for:		
<ul style="list-style-type: none"> Oil pressure too low. 	Check the oil level.	7.8 <i>Check the oil level, page 49</i>
<ul style="list-style-type: none"> Engine temperature too high. 	Check the cooling air guides for contamination or other impairments.	8.2.7 <i>Cleaning the cooling fan, cooling fins and oil cooler, page 63</i>

Possible causes	Remedy	Chapter
Irregularities in the electrical equipment:		
<ul style="list-style-type: none"> ▪ Loose contacts on cable connections. ▪ Faulty three phase alternator. ▪ Faulty relay. 	Check the electrical equipment and its components, contacting the service center if necessary.	3.2.4 <i>Electrical equipment, page 18</i>

The engine loses power and speed.

Possible causes	Remedy	Chapter
The speed adjustment lever does not stay in the desired position.	Block the speed adjustment.	
The fuel supply is impaired:		
<ul style="list-style-type: none"> ▪ The tank ran out of fuel during operation. ▪ Fuel prefilter or main fuel filter is clogged. 	Add fuel.	7.7 <i>Refueling, page 48</i>
	Change the fuel filter.	8.2.10 <i>Changing the fuel prefilter, page 69</i> 8.2.15 <i>Change the main fuel filter, page 79</i>
<ul style="list-style-type: none"> ▪ Inadequate tank venting. ▪ Line connections are not leak tight. 	Ensure that the tank is sufficiently vented. Check the line screw connections for leak tightness.	

The engine loses power and speed, and black smoke emerges from the exhaust

Possible causes	Remedy	Chapter
Dirty air filter unit.	Check the degree of dirt contamination of the air filter, and clean or renew it if necessary.	8.2.11 <i>Maintaining the dry air filter, page 71</i>
Tappet clearance not OK.	Adjust the tappet clearance.	8.2.13 <i>Check and set the tappet clearance, page 75</i>
Injection nozzle not OK.	Contact Hatz Service.	

Engine becomes very hot. Indicator lamp for engine temperature (option) lights up.

Possible causes	Remedy	Chapter
Too much engine oil in the engine.	Drain the engine oil to the upper mark of the dipstick.	7.8 <i>Check the oil level, page 49</i>
Inadequate cooling:		
<ul style="list-style-type: none"> Contamination in the entire area of the cooling air guides. 	Clean the cooling air area.	8.2.7 <i>Cleaning the cooling fan, cooling fins and oil cooler, page 63</i>
<ul style="list-style-type: none"> Incompletely closed air guide parts or capsule parts. 	Check the air guide parts and shafts for completeness and good sealing properties.	

9.2 Emergency start

Automatic electrical shutoff (option)

The identifying feature of the electrical automatic shutoff is brief flashing of all indicators after the starting key is turned to position "I".

NOTICE	
	<p>If the engine stops again immediately after starting, or stops independently during operation, this is an indication that a monitoring element of the automatic shutoff has been activated (see chapter 9.1 <i>Troubleshooting, page 87</i>).</p>

If the engine switches off due to an electrical fault signal or due to insufficient oil pressure with the aid of the automatic switch-off, an emergency start can be attempted by the user. The user must bear responsibility for any resulting damage.

This may be necessary if the vehicle stops at a critical location (railroad crossing or intersection).

When a monitoring element of the automatic switch-off is activated, the corresponding indicator lights up. After shutting down the engine, the indicator remains lit for approx. 2 minutes. The electrical equipment then switches off automatically.

Safety notes



CAUTION



Danger when switching off the engine from the emergency operation mode.

During the emergency operation mode, the engine can only be switched off with the starting key if the emergency start lever is first returned to its home position.

CAUTION

Danger of later engine damage.

The monitoring components (oil pressure, charge control and engine temperature) are deactivated in emergency operation.

- The oil level must be checked before the emergency operation phase.

NOTICE



If the emergency operation mode is used, the risk transfers to the operator (**the Motorenfabrik HATZ does not accept liability in this case**).

- Immediately after the emergency operation phase, determine the cause of the fault.
- Have the **Hatz service station** supply the emergency start lever with a new lead seal.

Overview

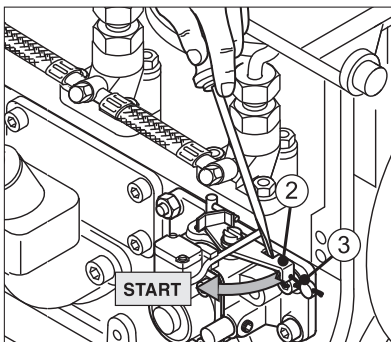

Pos.	Designation
2	Emergency start lever

Pos.	Designation
3	Seal wire









Procedure

Step	Activity
1	Check the oil level (see chapter 7.8 <i>Check the oil level</i> , page 49).
2	Remove the capsule hood or side trim panel (see chapter 5 <i>Engine design</i> , page 26)
3	Place a suitable tool, such as a screwdriver, behind the emergency start lever (2) and tear the seal wire (3) between the emergency start lever and the housing screw with a forceful jerk.
4	Turn the emergency start lever to the start position.
5	Start the engine (see chapter 7.5 <i>Starting the engine</i> , page 36).
6	Eliminate the emergency situation within a few seconds.
7	Switch off the engine.
8	Immediately after the emergency operation phase: <ul style="list-style-type: none"> ▪ Determine and remedy the cause of the fault signal (see chapter 9.1 <i>Troubleshooting</i>, page 87). ▪ If necessary, contact your nearest HATZ service station.

10 Storage and disposal

10.1 Storing the machine

Safety notes

 DANGER	
	<p>Danger to life from inhaling exhaust gases.</p> <p>Toxic engine exhaust gases can lead to loss of consciousness and even death in closed-off and poorly ventilated rooms.</p> <ul style="list-style-type: none"> ▪ Never operate the machine in closed-off or poorly ventilated rooms. ▪ Do not breathe in the exhaust gases.
 DANGER	
 	<p>Fire hazard from fuel.</p> <p>Leaked or spilled fuel can ignite on hot engine parts and cause serious burn injuries.</p> <ul style="list-style-type: none"> ▪ Only refuel when the engine is switched off. ▪ Never refuel in the vicinity of open flames or sparks that can cause ignition. ▪ Do not smoke. ▪ Do not spill fuel.
 CAUTION	
	<p>Danger of environmental damage from spilled fuel.</p> <p>Do not overfill the fuel tank and do not spill fuel.</p> <ul style="list-style-type: none"> ▪ Collect any leaking fuel and dispose of it according to local environmental regulations.
NOTICE	
	<p>Comply with the safety chapter!</p> <p>Follow the basic safety instructions in chapter 3 <i>Safety</i>, page 7.</p>

Storing the machine for a lengthy period

Take the following measures if you intend to take the machine out of service for a lengthy period (3-12 months):

Step	Activity
1	Drain the fuel tank until it is nearly empty and fill with FAME*-free fuel. Operate the engine for a few minutes so that only FAME-free fuel is still in the fuel system.
2	Change the engine oil and oil filter (see chapters 8.2.5 <i>Change the engine oil, page 60</i> and 8.2.14 <i>Changing the oil filter, page 78</i>).
3	Change the fuel filter (see chapter 8.2.15 <i>Change the main fuel filter, page 79</i>).
4	Let the machine cool down.
5	Remove the battery in accordance with the machine operators manual and store at ambient temperature. Comply with the local regulations as well as the regulations of the battery manufacturer for the storage of batteries.
6	Close and seal all engine openings (air intake openings, air outlet openings and the exhaust gas opening) so that no foreign bodies can enter, but a small amount of air can still be exchanged. This avoids condensation.
7	After the machine has cooled down, cover it to protect it against dust and store it in a dry and clean place.

*FAME = Fatty Acid Methyl Ester

Ambient conditions during storage

- Max. permissible storage temperature: -25 °C to +60 °C
- Max. permissible humidity: 70%
- Protect the engine from direct sunlight

Recommissioning

Step	Activity
1	Remove all covers.
2	Check the cables, hoses and lines for cracks and leak tightness.
3	Check the engine oil level.
4	Install the battery in accordance with the Operator's Manual for the machine.

The brand new engine can normally be stored for up to 12 months. The protection lasts up to approx. 6 months at very high humidity and with sea air.

For storage periods of more than 12 months, please contact the nearest **Hatz service**.

10.2 Disposing of the machine

Disposal information

Dispose of the machine (including machine parts, engine oil and fuel) according to the local disposal regulations and the environmental laws in the country of use.

Because of the danger of possible environmental damage, only permit an approved specialist company to dispose of the machine.

NOTICE



When the machine has reached the end of its lifecycle, ensure that it is disposed of safely and properly, especially parts and substances that can be dangerous to the environment. These also include fuel, lubricants, plastics, and batteries (if present).

- Do not dispose of the battery with the household trash.
- Dispose of the battery at a collection point for possible recycling.

11 Proof of quality

Proof of quality

The manufacturer: **Motorenfabrik Hatz GmbH & Co.KG**
Ernst-Hatz-Straße 16
D-94099 Ruhstorf a. d. Rott

hereby declares that the incomplete machine: product description: **Hatz diesel engine**

Type designation and as of serial number:

2L41=15310;

2M41=15410

satisfies the following basic safety and health protection requirements in acc. with Annex I of the EC Machinery Directive 2006/42/EC.

- General principles no. 1

- Nr. 1.1.2., 1.1.3., 1.1.5., 1.2.1., 1.2.2., 1.2.3., 1.2.4.1., 1.2.4.2., 1.3.1., 1.3.2., 1.3.3., 1.3.4., 1.3.7., 1.3.9., 1.4.1., 1.5.1., 1.5.2., 1.5.3., 1.5.8., 1.5.9., 1.6.1., 1.6.2., 1.6.4., 1.7.

All relevant basic safety and health protection requirements down to the interfaces described

- in the manual for diesel engine
- in the enclosed data sheets
- in the enclosed technical documents

have been complied with.

The special technical documents in acc. with Annex VII B of the Directive 2006/42/EC have been prepared.

Conformity with the provisions of the following, other EC Directives, i.e.

- **2014/30/EU Electromagnetic Compatibility (EMC)**, dated 26.02.2014
(was tested in association with a generating set)

The following standards have been used (completely or partially):

- EN 1679-1: 092011
- EN ISO 12100: 032011
- EN ISO 13857: 062008
- EN 60204-1: 062007
- EN ISO 13849-1: 062016

The manual for diesel engine has been enclosed to the incomplete machine and the Assembly Instructions have been provided to the customer electronically together with the order confirmation.

Commissioning has been prohibited until it has been established, if applicable, that the machine into which the above-mentioned incomplete machine is to be incorporated, satisfies the provisions of the respective federal state.

12 EPA CERTIFIED ENGINES

**SUPPLEMENTAL INFORMATION
TO THE OWNER'S MANUAL FOR MODEL YEAR 2019
EPA CERTIFIED
NONROAD COMPRESSION IGNITION ENGINES**

**EPA EMISSION CONTROL SUPPLEMENTAL
WARRANTY STATEMENT AND
EMISSION-RELATED INSTALLATION INSTRUCTIONS**

MAINTENANCE AND WARRANTY.**SUPPLEMENTAL INFORMATION TO THE OWNER'S MANUAL FOR MODEL YEAR 2019 EPA CERTIFIED NONROAD COMPRESSION IGNITION ENGINES.**

The following supplemental information is furnished for EPA Nonroad Compression Ignition Engines which are certified according to 40 CFR Part 89 and Part 1039.

This information contains the following specific items:

- EPA-related engine parts and engine operating conditions
- Maintenance instructions for EPA-related engine parts
- Emission control system and adjustments
- Warranty statement
- Emission-related installation instructions

ENGINE PARTS AND / OR EQUIPMENT RELATED TO EPA EXHAUST EMISSION REGULATIONS.

Parts which are mandatory for engine operation.

The following parts as manufactured according to HATZ specifications are mandatory for engine operation which meets EPA exhaust emission regulations.

- Fuel Injection pump(s)
- Injection nozzle(s)
- Cold start device
- Intake and exhaust manifold
- Crankcase breather valve assembly
- Oil filler cap
- Vacuum switch
- Solenoids
- Wiring harnesses
- Fuel hoses
- Intake and exhaust gaskets
- Emission Control Information Labels

Only parts manufactured by Hatz and which have passed the Hatz Quality Assurance Program are assured of meeting EPA exhaust emission regulations.

UNUSUAL OPERATING CONDITIONS.

The engine must not be operated at a load factor less than 25 % for an extended period as such operation will cause the fuel injector to foul. If such a condition occurs, you should contact the nearest HATZ authorized Service Center for necessary repairs.

The engine is designed and adjusted to operate most efficiently at the following conditions:

- Air temperature of 25° C (77° F)
- Atmospheric pressure of 100 kPa (14.5 psi)
- Relative humidity of 30 %

Operation of the engine at conditions other than above will affect performance and exhaust emissions. Normally the equipment manufacturer takes this into account during the design of the machine and your equipment will perform within specifications over a wide range of climatic conditions. However if you must operate your equipment under very unusual climatic conditions, please contact your nearest Hatz distributor for advice.

MAINTENANCE SCHEDULE-EPA-RELATED PARTS

The following minimum intervals are being adopted for adjustment, cleaning, repair, or replacement of following components:

At 1.500 hours, and 1.500-hours intervals thereafter:

- Fuel injector tips (cleaning only)

At 3.000 hours, and 3.000-hours intervals thereafter:

- Fuel injector(s)

The exhaust quality of the engines can be influenced by the execution (the quality of execution) of above described maintenance work.

Therefore, the maintenance work has to be carried out by a qualified workshop.

Hatz authorised workshops, for example, are qualified workshops.

Hatz Diesel of America will give you respective addresses, if required.

EMISSION CONTROL SYSTEM AND ADJUSTMENTS.

The emission control system for the engine series **2L41C** and **2M41** is DI (Direct Injection) and EM (Engine Modification).

No adjustments are needed or possible.

EPA EMISSION CONTROL WARRANTY STATEMENT

YOUR WARRANTY RIGHTS AND OBLIGATIONS.

Motorenfabrik Hatz GmbH & Co. KG warrants the emission control system on your engine for the periods of time listed below provided there has been no abuse, neglect or improper maintenance of your engine.

Your emission control system includes:

- Fuel Injection pump(s)
- Injection nozzle(s)
- Cold start device
- Intake and exhaust manifold
- Crankcase breather valve assembly

- Oil filler cap
- Vacuum switch
- Solenoids
- Wiring harnesses
- Fuel hoses
- Intake and exhaust gaskets
- Emission Control Information Labels

Where a warrantable condition exists, Motorenfabrik Hatz will repair your engine at no cost to you including diagnosis, parts and labor.

MANUFACTURERS WARRANTY COVERAGE

The emission control related parts of Model Year 2019 engines are warranted as follows:

POWER RATING	RATED ENGINE SPEED	WARRANTY PERIOD	
[kW]	[rpm]	[hours]*	[years]*
37 ≤ kW < 75	All	3000	5
19 ≤ kW < 37	All	3000	5
19 ≤ kW < 37	constant speed, ≥3000	1500	2
kW < 19	All	1500	2

* Whichever occurs first

If any emission related part on your engine is defective, the part will be repaired or replaced by Motorenfabrik Hatz.

OWNER'S WARRANTY RESPONSIBILITIES.

- As the engine owner, you are responsible for the performance of the required maintenance listed in your owner's manual. Motorenfabrik Hatz recommends that you retain all receipts covering maintenance on your engine, but Motorenfabrik Hatz cannot deny warranty solely for the lack of receipts or for your failure to ensure the performance of all scheduled maintenance.
- As the engine owner, you should be aware, however, that Motorenfabrik Hatz may deny you warranty coverage if your engine or a part has failed due to abuse, neglect, improper maintenance or unapproved modifications.
- You are responsible for presenting your engine to a Motorenfabrik Hatz authorized service center as soon as a problem exists. The warranty repairs should be completed in a reasonable amount of time, not to exceed 30 days.
- If you have any questions regarding your warranty rights and responsibilities, you should contact HATZ DIESEL OF AMERICA, Inc. at (262)-544-0254.

HATZ DIESEL SUPPLEMENTAL WARRANTY FOR MODEL YEAR 2019 EPA CERTIFIED ENGINES.

PARTS WITH SUPPLEMENTAL LIMITED WARRANTY.

The following limited warranty is supplemental to the standard HATZ DIESEL LIMITED ENGINE WARRANTY and covers Model Year 2019 EPA certified engines and applies to the following exhaust emission-related components:

- Fuel Injection pump(s)
- Injection nozzle(s)
- Cold start device
- Intake and exhaust manifold
- Crankcase breather valve assembly
- Oil filler cap
- Vacuum switch
- Solenoids
- Wiring harnesses
- Fuel hoses
- Intake and exhaust gaskets
- Emission Control Information Labels

SUPPLEMENTAL LIMITED WARRANTY.

Hatz Diesel of America, Inc. hereinafter referred to as "HATZ" warrants each of the above-listed parts when installed in a new engine sold by Hatz to be free from defects in material and workmanship under normal use and service, only under the named warranty coverage conditions, after the date of delivery to the original retail purchaser and Hatz will at their option, repair or replace at Hatz's sales headquarters, or at a point designated by Hatz, any part or parts which shall appear to the satisfaction of Hatz upon inspection at such point, to have been defective in material or workmanship.

- Any warranted part which is scheduled for replacement as required maintenance is warranted for the period of time up to the first scheduled replacement point for that part.
- Any replacement part which is equivalent in performance and durability may be used in non-warranty maintenance or repairs and will not reduce the overall engine warranty obligations of Hatz. However, Hatz is not responsible for failure of such replacement parts or failure of any other parts directly caused by failure of such replacement parts.
- This warranty does not obligate Hatz to bear any transportation charges in connection with the repair or replacement of defective parts. This warranty is transferrable to subsequent owners, only under the named warranty coverage conditions.

- In order to obtain service under this warranty, the retail purchaser should contact Hatz Diesel of America, Inc. at (262)-544-0254 for information and the nearest service center. The retail purchaser will not be charged for diagnostic labor which leads to the determination that a warranted part is defective, nor for the repair or replacement of warranted parts if the work is performed at an authorized Hatz service center. If other engine components are damaged due to a failure of the above-listed warranted parts still under warranty, these other engine components will also be repaired or replaced at no charge.
- This warranty shall not apply to any engine which shall have been installed or operated in a manner not recommended by Hatz, nor to any engine which shall have been repaired, altered, neglected, or used in any way which, in the opinion of Hatz, adversely affects its performance, nor to any engine in which parts not authorized by Hatz have been used, which parts or the use of which have damaged or caused defects in or otherwise adversely affected the engine or its performance, nor to normal maintenance service or replacement of normal service items.

Hatz reserves the right to modify, alter, and improve any engine or parts without incurring any obligation to replace any engine or parts previously sold with such modified, altered, or improved engine or parts.

EMISSION-RELATED INSTALLATION INSTRUCTIONS

“Failing to follow these instructions when installing a certified engine in a piece of nonroad equipment violates federal law (40CFR1068.105(b)), subject to fines or other penalties as described in the Clean Air Act.”

“If you install the engine in a way that makes the engine's emission control information labels hard to read during normal engine maintenance, you must place duplicate labels on the equipment.”

EQUIPMENT-LABELLING REQUIREMENTS: FUEL LABEL (see chapter 3.3 Labels, page 20)

The fuel label has to be permanently attached to the equipment.

In case of an engine mounted fuel tank, every engine is equipped with an additional fuel label nearby the fuel inlet.

Otherwise, there are two loose fuel labels available with the engine.

If the original fuel label is not readily visible after the engine is installed in the equipment then the second loose fuel label must be attached on the equipment in such a manner that it is readily visible to an average person.

INSTRUCTIONS ON THE INSTALLATION OF THE EXHAUST SYSTEM

Following are the instructions to properly install the exhaust system and related components consistent with the EPA emission regulation requirements.

2M41, 3M41, 4M41

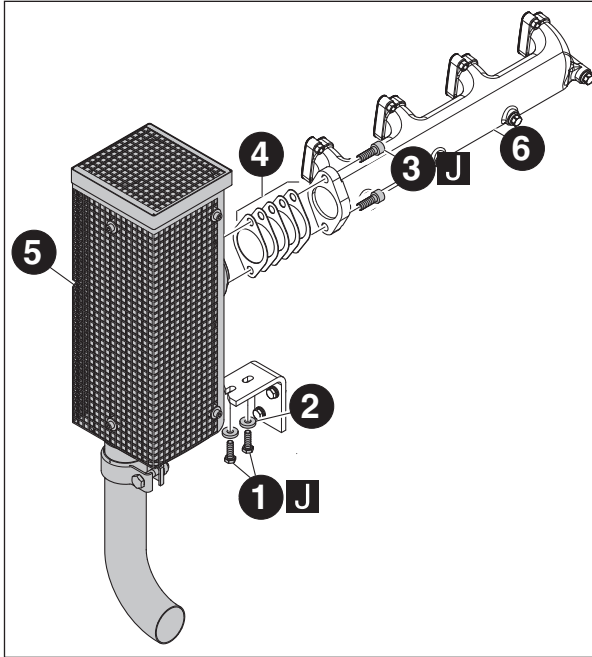

Exhaust-silencers

The exhaust silencer is fitted in connection with gaskets. Fixation is done by hexagon head screws (1) and Allen screws (3).

Dismantling:

- Remove in numerical sequence (1...5).

Assembly:

- Assemble in reverse sequence.
- Use anti-seize compound **J** as specified by HATZ.

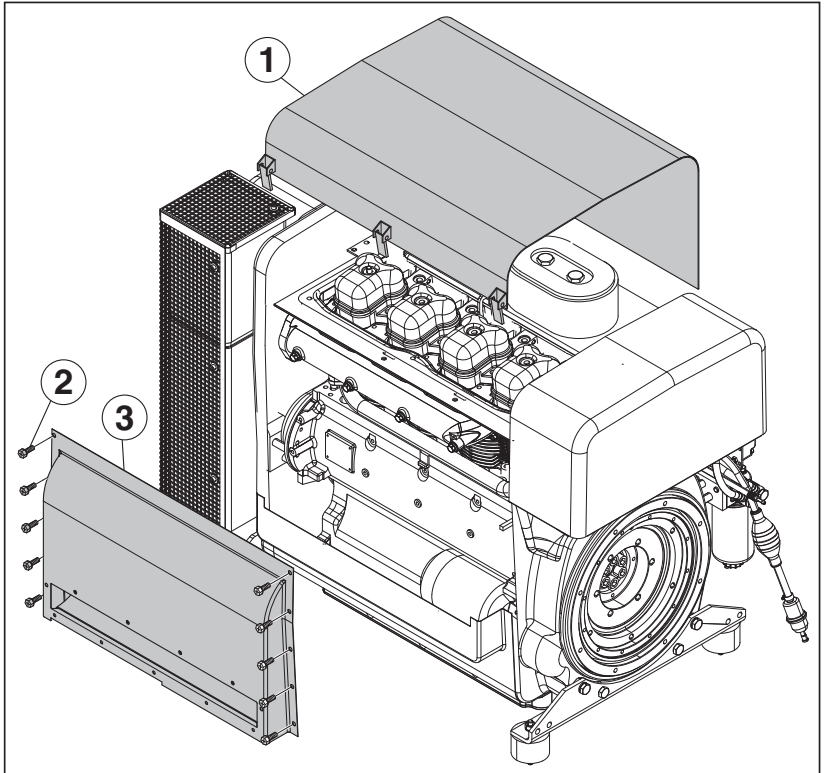
2L41C, 3L41C, 4L41C**Encapsulated engine**

Before dismantling the exhaust system the capsule has to be dismantled:

- Remove the top cover (1) by opening the clips.
- Remove all screws (2) and remove the side cover (3).

Assembly:

- Assemble in reverse sequence.
- Before tightening the capsule all screws have to be turned in and the different covers have to be correctly adjusted.

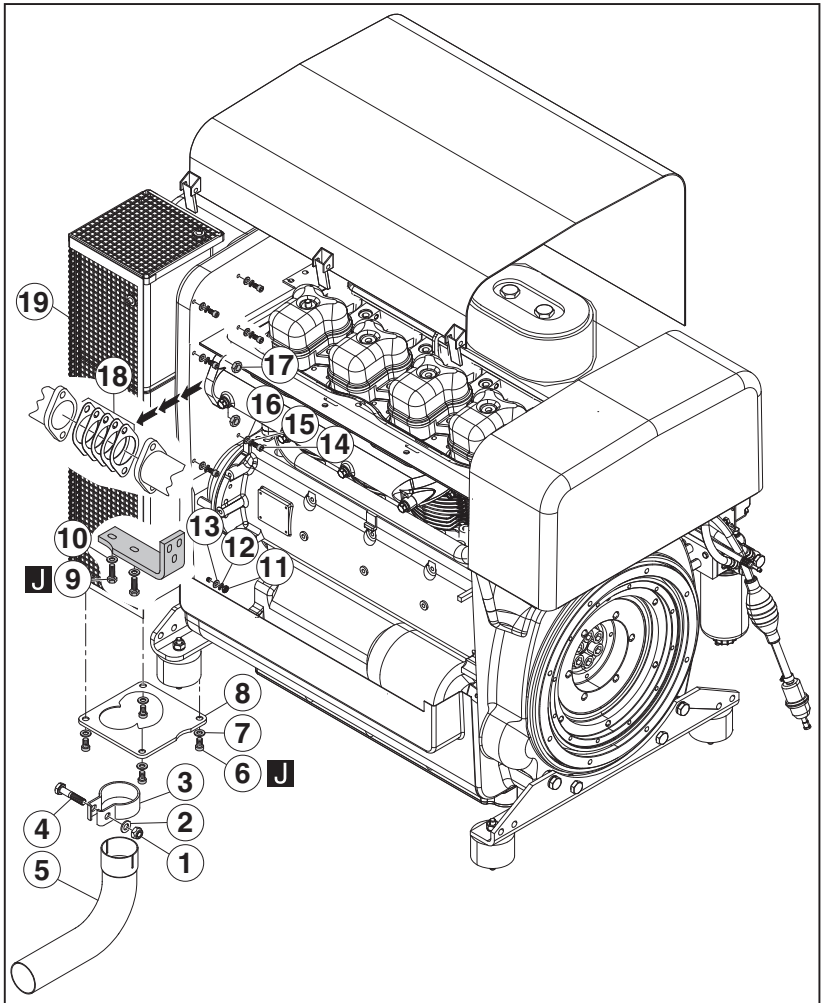

Sequence of dismantling the exhaust system:

- Open nut (1) and remove in numerical sequence (2...5).
- Open screws (6) and remove with shims (7) and plate (8).
- Open screws (9) and remove with shims (10).
- Open nuts (11) and remove with snap ring (12) and shim (13).
- Open all Allen screws (14) and remove with snap rings (15) and shims (16).
- Open and remove both nuts (17).
- Remove silencer (19) with five identical gaskets (18).

Assembly:

- Assemble in reverse sequence.
- Make sure that all parts are correctly placed and tightened.
- Use anti-seize compound J as specified by HATZ.

SAMPLING OF EXHAUST EMISSIONS

After the engine is installed in the equipment and placed in service, the sampling of exhaust emissions can be performed in a way that prevents diluting the exhaust sample with ambient air as follows:

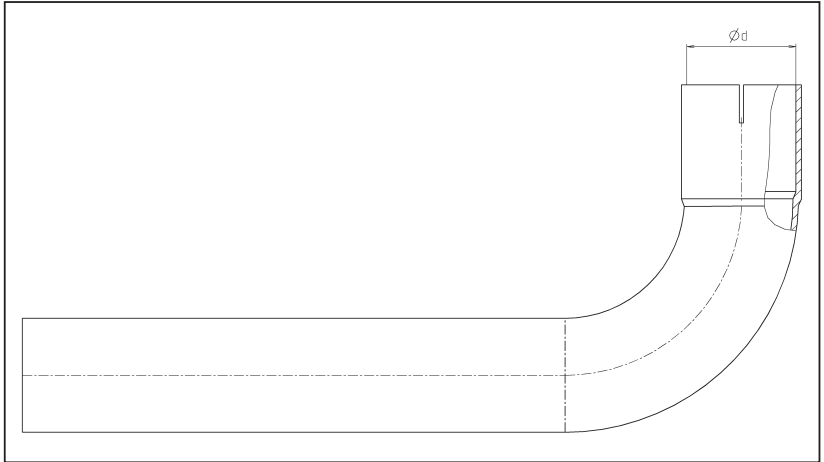

Specification: Adding a 20-centimeter bended extension to the exhaust pipe.

Engine type	Ø d (mm)	HATZ-Ident. Nr.	Clamp HATZ-Ident. Nr.
2L41C	48	0000 038 775 00	0000 504 103 01
2M41	55	0000 038 776 00	0000 038 778 00

13 EPA CERTIFIED ENGINES WITHIN CALIFORNIA

**SUPPLEMENTAL INFORMATION
TO THE OWNER'S MANUAL
FOR THE USE OF EPA CERTIFIED ENGINES
WITHIN CALIFORNIA.**

The following information is taken from the official CARB website and this page was last reviewed October 31, 2012. For the latest information please see <http://www.arb.ca.gov/msprog/offroad/preempt.htm>

"The 1990 amendments to the federal Clean Air Act preempt California control of emissions from new farm and construction equipment under 175 horsepower. Emissions from these new engines are beyond ARB's authority to regulate. The U.S. EPA has sole authority to establish emission standards for these preempt engines used in new farm and construction equipment under 175 horsepower. However, these equipment types may become subject to ARB's In-Use Off-Road Vehicle Regulations which target diesel particulate matter (PM) and oxides of nitrogen (NOx) emissions from in-use (existing) off-road heavy-duty diesel vehicles, and hydrocarbons (HC) and NOx emissions from in-use large spark-ignition (LSI) engine forklifts and other industrial equipment. For more information, please refer to ARB's In-Use Off-Road Vehicle Regulations web pages for in-use off-road diesel vehicles (<http://www.arb.ca.gov/msprog/ordiesel/ordiesel.htm>) requirements.

Below is a description of applications for determining preempted equipment. Please also see information regarding the federal non-road engine emissions control program (<http://www.epa.gov/nonroad/>)

The following exemption list has been modified. At the request of industry, staff has removed the term "Cleaners: high pressure" from the exemption list to avoid confusion with pressure washers. This modification is intended to clarify the ARB's interpretation that pressure washers have never been considered exempt equipment.

Equipment types with engines less than 25 horsepower are presumed not to be construction or farm equipment, with the exception of the following equipment types, which have been determined to be construction or farm equipment:

▪ Aerial devices: vehicle mounted	▪ Burners: bituminous equipment
▪ Asphalt recycler/reclaimer, sealer	▪ Cable layers
▪ Augers: earth	▪ Chainsaws 45 cc and above
▪ Back-hoe	▪ Chippers
▪ Backpack Compressors	▪ Cleaners: steam, sewer, barn
▪ Baler	▪ Compactor: roller/plate
▪ Boring machines: portable line	▪ Compressors
▪ Breakers: pavement and/or rock	▪ Concrete buggy, corer, screed, mixer, finishing equipment
▪ Brush cutters/Clearing saws 40 cc and above (blade capable only)	▪ Continuous Digger

▪ Conveyors: portable	▪ Power pack: hydraulic
▪ Crawler excavators	▪ Pruner: orchard
▪ Crushers: stone	▪ Pumps 40 cc and above
▪ Cultivators: powered	▪ Rollers: trench
▪ Cutting machine	▪ Sawmill: portable
▪ Debarker	▪ Saws: concrete, masonry, cutoff
▪ Detassler	▪ Screeners
▪ Drills	▪ Shredder/grinder
▪ Dumper: small on-site	▪ Signal boards: highway
▪ Dusters	▪ Silo unloaders
▪ Elevating work platforms	▪ Skidders
▪ Farm loaders: front end	▪ Skid-steer loaders
▪ Feed conveyors	▪ Specialized fruit/nut harvester
▪ Fertilizer spreader	▪ Sprayers: bituminous, concrete curing, crop, field
▪ Forage box/Haulage and loading machine	▪ Stump cutters, grinders
▪ Forklifts: diesel and/or rough terrain	▪ Stumpbeater
▪ Harvesters, crop	▪ Surfacing equipment
▪ Jackhammer	▪ Swathers
▪ Light towers	▪ Tampers and rammers
▪ Mixers: mortar, plaster, grout	▪ Tractor: compact utility
▪ Mowing equipment: agricultural	▪ Trenchers
▪ Mud jack	▪ Troweling machines: concrete
▪ Pavers: asphalt, curb and gutter	▪ Vibrators: concrete, finisher, roller
▪ Pipe layer	▪ Welders
▪ Plows: vibratory	▪ Well driller: portable
▪ Post hole diggers	▪ Wheel loaders



WARNING: Breathing diesel engine exhaust exposes you to chemicals known to the State of California to cause cancer and birth defects or other reproductive harm.

- Always start and operate the engine in a well-ventilated area.
- If in an enclosed area, vent the exhaust to the outside.
- Do not modify or tamper with the exhaust system.
- Do not idle the engine except as necessary.

For more information go to www.P65warnings.ca.gov/diesel

043 550 00

Motorenfabrik Hatz GmbH & Co. KG

Ernst-Hatz-Str. 16

94099 Ruhstorf a. d. Rott

Deutschland

Tel. +49 8531 319-0

Fax. +49 8531 319-418

marketing@hatz-diesel.de

www.hatz-diesel.com



CREATING POWER SOLUTIONS.

0000 433 415 16 - 01.2019 - 0.1

Printed in Germany

USA - EPA IV